

LINC-NIRVANA

The **L**BT **I**nterferometric **C**amera and
Near-**I**nfra**R**ed / **V**isible **A**daptive
interferometer for **A**stronomy

A collaborative project of the MPIA Heidelberg, INAF-Arcetri,
Universität zu Köln, and MPIfR Bonn

<http://www.mpia.de/LINC>

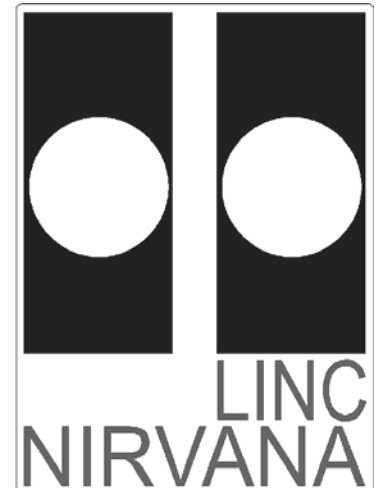

LINC-NIRVANA

-

Design of the cryostat

Doc. No. LN-MPIA-FDR-CRY-002
Short Title Cryostat
Issue 1.2
Date 25 April 2005

Prepared	<u>Werner Lau</u>	<u>25 April 2005</u>	
	Name	Date	Signature
Approved	<u>Peter Bizenberger</u>	<u>5 May 2005</u>	
	Name	Date	Signature
Released	<u>Martin Kürster</u>	<u>20 May 2005</u>	
	Name	Date	Signature

Document Change Record

Issue	Date	Section/ Paragraph Affected	Reasons / Remarks
1.0	25 April 2005	All	new document
1.1	5 May 2005	All	approved version
1.2	20 May 2005	All	released version

TABLE OF CONTENTS

1	Scope	5
2	Applicable documents	5
3	External Interfaces	5
4	Acronyms and abbreviations	5
5	Introduction	6
6	Functions	6
7	Cooling unit	6
7.1	Purpose.....	6
7.2	Requirements.....	6
7.3	Parts.....	7
7.4	Layout.....	7
7.5	Functionality.....	8
7.6	Specification.....	9
7.7	Availability.....	17
8	Heat exchanger	17
8.1	Purpose.....	17
8.2	Requirements.....	17
8.3	Parts.....	18
8.4	Layout.....	19
8.5	Functionality.....	20
8.6	Specification.....	20
8.7	Availability.....	21
9	Vacuum can	21
9.1	Purpose.....	21
9.2	Requirement	21
9.3	Parts.....	21
9.4	Layout.....	22
9.5	Functionality.....	22
9.6	Specification.....	23
9.7	Availability.....	25
10	Spacers	25
10.1	Purpose.....	25
10.2	Requirements.....	25

10.3	Layout	25
10.4	Functionality	26
10.5	Specification.....	26
10.6	Availability.....	26
11	Mounting and dismounting of the cryostat	26
11.1	Purpose.....	26
11.2	Requirements	27
11.3	Parts.....	27
11.4	Layout	28
11.5	Functionality	30

LIST OF TABLES

Table 1: Parts of the vacuum system	21
---	----

LIST OF FIGURES

Figure 1: Schematic layout of the cooling unit, to be mounted on level 4 of the LBT observatory	7
Figure 2: Dimension of the SPC-1 cooler, left: side view, right: top view.....	9
Figure 3: Cooling power of SPC-1 cryocooler	10
Figure 4: SPC-1 power consumption.....	10
Figure 5: Location of the cooler at the telescope	11
Figure 6 : Heat exchanger with fan blower on the cold end of the cooler	12
Figure 7: Characteristics of the fan blower at different speed	13
Figure 8: routing of the lines at the telescope	14
Figure 9: transfer line connector	15
Figure 10: size of one bundle of He- bottles, left: front view, right: side view	16
Figure 11: heat exchanger	19
Figure 12: tube ends for inlet and outlet	19
Figure 13: mounting ring for the cold structure.....	20
Figure 14: Schematic diagram of the vacuum system	22
Figure 15: View of the cryostat vacuum vessel	23
Figure 16: View of the cryostat vacuum vessel	24
Figure 17: Spring loaded overpressure safety valve	24
Figure 18: Spacer at the top flange of the cryostat	25
Figure 19: Spacer at the bottom of the cryostat	26
Figure 20: vacuum can with built-in heat exchanger.....	28
Figure 21: disassembly of the cryostat in a sequence of pictures	29

1 Scope

This document describes the cryostat of the LINC-NIVANA instrument, including the cooling unit which is mounted remotely.

2 Applicable documents

No.	Title	Number & Issue
AD1	IR Beam Combining Optics	LN-MPIA-FDR-OPT-002
AD2	Cryomechnisms	LN-MPIA-FDR-CRY-001
AD3	FFTS Hardware	LN-KOELN-FDR-CRY-001
AD4	Optical bench	LN-MPIA-FDR-INT-201
AD5	Science detector electronics	LN-MPIA-FDR-INT-204
AD6	FFT detector electronics	LN-MPIA-FDR-INT-205
AD7	Cabinets and cabling electrical	LN-MPIA-FDR-INT-206
AD8	NIR optics mechanical	LN-MPIA-FDR-INT-207
AD9	FFT electrical	LN-MPIA-FDR-INT-208
AD10	FFT mechanical	LN-MPIA-FDR-INT-209
AD11	Heat exchanger design report	LN-MPIA-FDR-CRY-002-APP_A
AD12	User manual cryocooler	LN-MPIA-FDR-CRY-002-APP_B
AD13	Service manual cryocooler	LN-MPIA-FDR-CRY-002-APP_C

3 External Interfaces

Item	Short description
Helium transfer lines to the telescope	The helium transfer lines are mounted to the enclosure and the telescope structure
services	The cooler needs cooling water, power and Ethernet connection

4 Acronyms and abbreviations

All acronyms and abbreviations are explained where they appear.

5 Introduction

The cryostat is essential for operating the IR detectors and achieving low background for useful science observations. It is also important in maintaining a well-defined configuration of the optics. Any temperature change, flexure or vibration will lead to a differential spacing in the individual optical components.

6 Functions

- Cooling unit with helium transfer lines
- Heat exchanger
- Vacuum can
- Spacers
- Mounting and dismounting of the cryostat

7 Cooling unit

7.1 Purpose

The cryogenic cooling concept of the LINC NIRVANA cryostat is a new approach to design a cooling system with very low vibrations to make it usable for an interferometric instrument. We therefore keep the cooler away from the instrument and transport cold gas through a vacuum isolated transfer line to a heat exchanger inside the cryostat.

7.2 Requirements

Mechanical requirements

- Low vibration

Thermal requirements:

- Should bring a cooling power of at least 200 W at a temperature of 60 K to the cryostat
- Should be able to cool the cryostat down from 300 K to 60 K in less than 48 h
- Should be able to warm up the cryostat from 60 K to 300 K in less than 24 h.
- Should be able to stabilize the cryostat temperature in the range of 50 to 100 K with a stability of +/- 1K
- For all parts the general thermal requirements in case of surface temperature and heat dissipation are valid.
- Should work in an environment temperature -20 to 25°C

7.3 Parts

- Stirling cooler type SPC-1
- heat exchanger cold head to helium
- fan blower
- vacuum isolated transfer lines
- electronic control unit
- frequency converter
- helium buffer tank
- gas to air heat exchanger
- thermally isolated housing

7.4 Layout

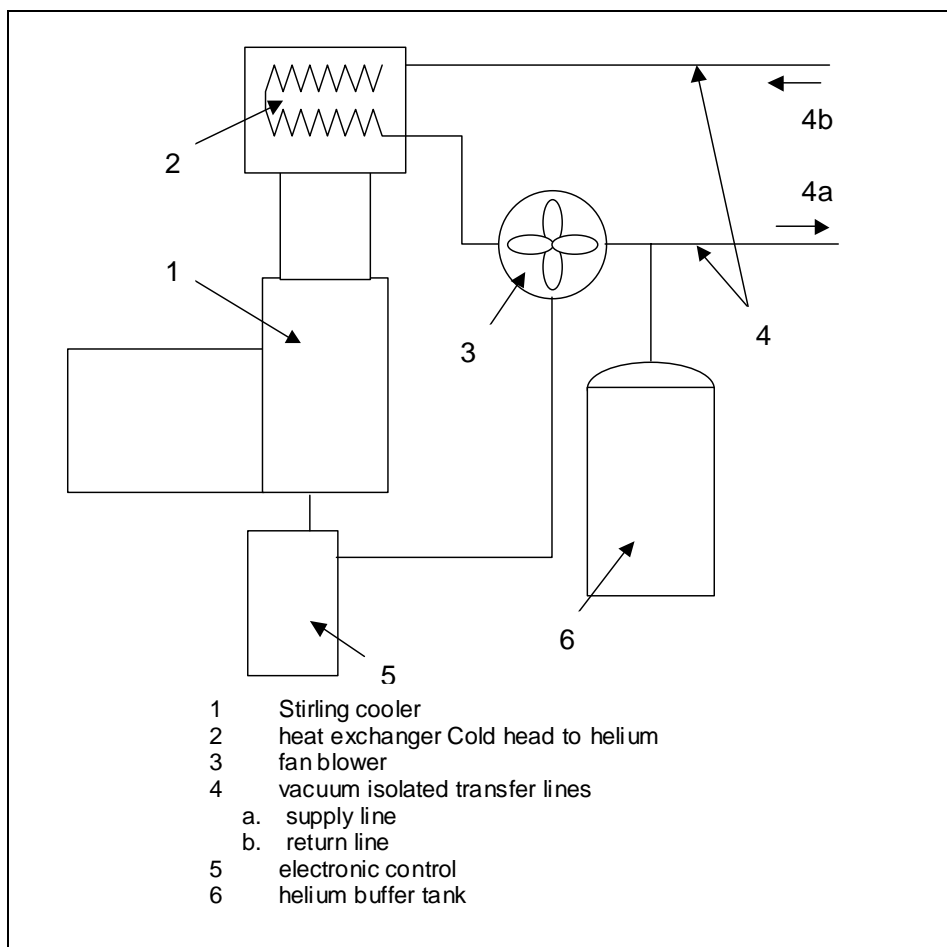

Figure 1: Schematic layout of the cooling unit, to be mounted on level 4 of the LBT observatory

7.5 Functionality

The cooling unit supplies a flow of cold Helium gas controlled in flow speed and cooling power. The temperature can be adjusted between ambient temperature and a theoretical minimum of 45 K. The helium has a pressure of about 25 bars, depending on flow and temperature.

- **Stirling cooler**

We use an industrial cooler from Stirling which supplies cryogenic temperatures with high cooling power. The cooler is driven by a frequency converter to change the cooling power. Also, the pressure of the working gas inside the cooler can be changed to reduce the cooling power if required.

- **Heat exchanger cold head to helium**

On the cold head of the Stirling cooler, a heat exchanger will efficiently cool the flow of helium gas by using the heat sink of the cooler. A heating at the heat exchanger is built in to warm up the helium in the loop and therefore the cryostat. The heat exchanger is thermally isolated from the outside world.

- **Fan blower**

The cold helium gas is pumped in a loop using a fan blower with variable speed. The speed can be reduced by the electronic unit but it is usually running at full speed. The pressure of the blower is high enough to transport the required helium flow rate through the lines and the heat exchanger inside the cryostat.

- **Vacuum isolated transfer lines**

The transfer lines transport the cold helium gas from the cooler to the cryostat and back. They are thermally isolated to reduce heat input. The cross section allows a sufficient flow rate.

- **Electronic control unit**

The electronic control unit drives the cooler and the fan blower. Both are variable in speed and can be controlled by this unit. A control loop can be closed using the temperature information from the cryostat and the temperature set point from the control electronics. The cooling power can also be controlled to have a defined cool down rate. Additionally it can also control the warm up heater and control the warm up rate. The control unit has several alarm outputs. There is a data interface to the instrument control electronics.

- **Helium buffer tank**

Any change in temperature results in a change in helium pressure in the transfer lines and the cryostat heat exchanger. To keep this temperature change small, we connect a warm buffer volume with a helium volume larger than the volume of the helium loop. Temperature changes in the loop will therefore result in a smaller temperature change, because the buffer is always warm.

- **Gas to Air heat exchanger**

The change in helium pressure when warming up the cryostat causes a flow of cold helium from the loop to the buffer volume. As this helium is still cold compared to outside temperature the buffer volume would freeze and probably leak. The gas to air heat exchanger will bring the helium almost to ambient temperature before it enters the buffer volume.

- **Housing**

The housing should on one side reduce the power loss to air and on the other side keep the inside temperature within the working temperature range of the cooler. The cooler and an air to water heat exchanger inside the housing will be supplied with 6°C cooling water-glycol. This will keep

the inside temperature in the working range of the cooler. The housing will also include vibration damping to reduce vibrations from the cooler as much as possible. These vibrations would couple to the dome, not the telescope.

7.6 Specification

- **Stirling cooler**

For detailed specification see the Stirling manual

Size of the SPC-1 cryogenerator from Stirling

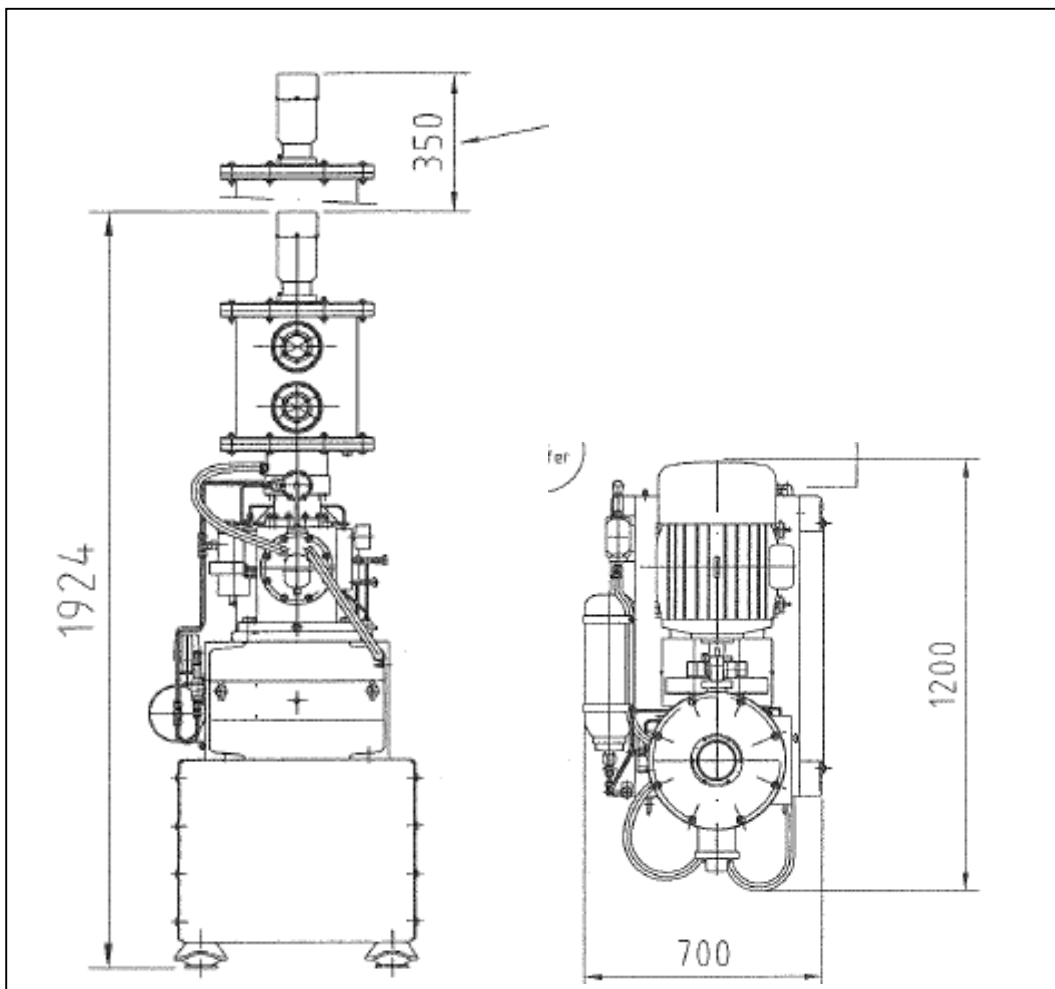

Figure 2: Dimension of the SPC-1 cooler, left: side view, right: top view

Cooling Power

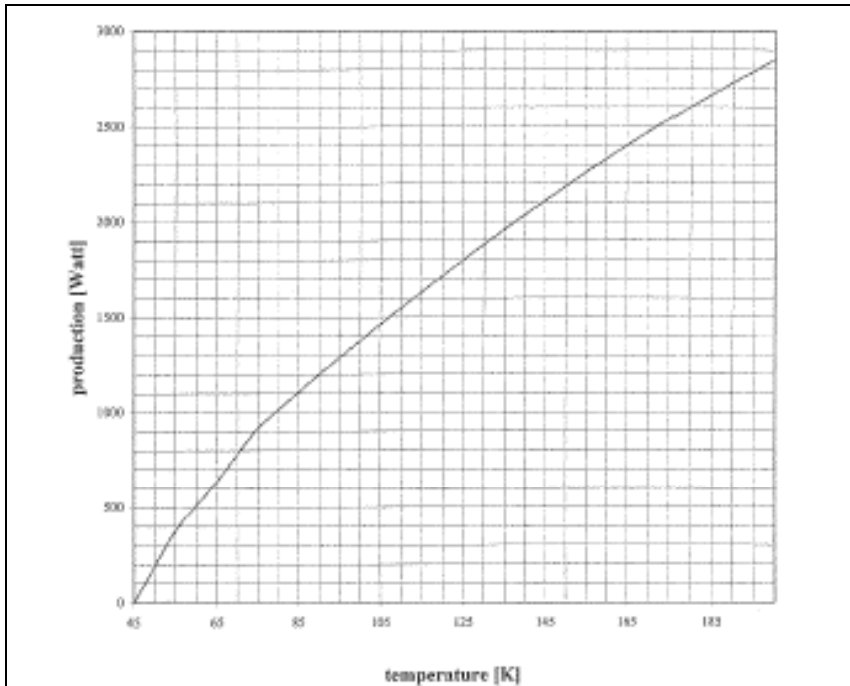

Figure 3: Cooling power of SPC-1 cryocooler

Power consumption

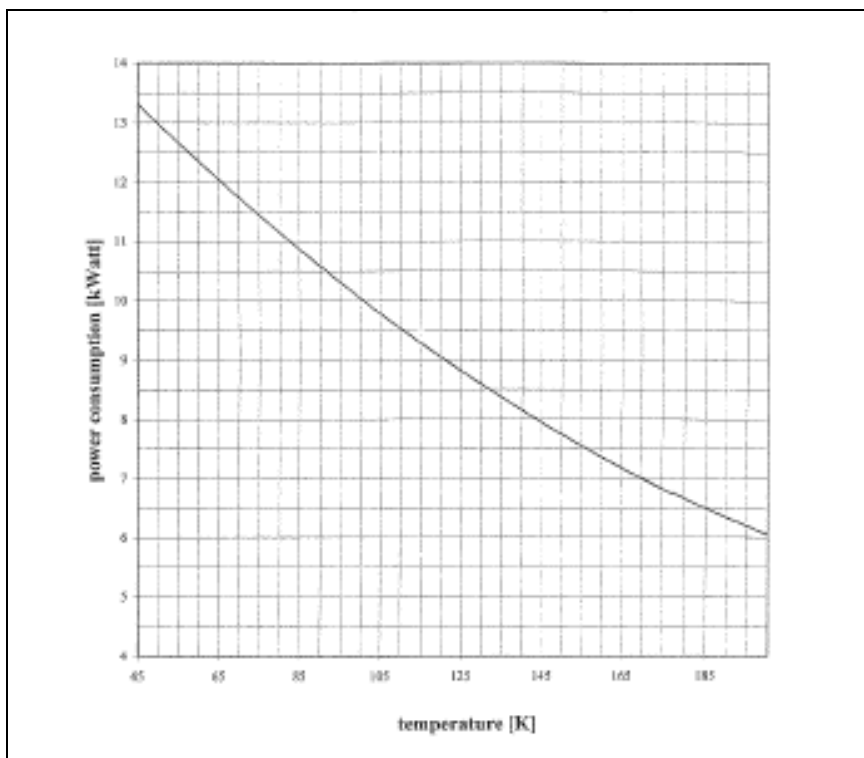

Figure 4: SPC-1 power consumption

Cooling water-glycol

850 l/h at 15°C

Working temperature

5 to 30°C

Location of the cooler at the telescope

The cooler has to stay away from the telescope because of vibration. A place in the building is the 4th level in the room where the large ventilation system is placed. This is also a part of the rotating building. Because this room will be at outside temperature, the cooler has to be housed in a box, because it can not be operated below 5°C. The location and the dimension of this housing is being neglected with the LBTO.

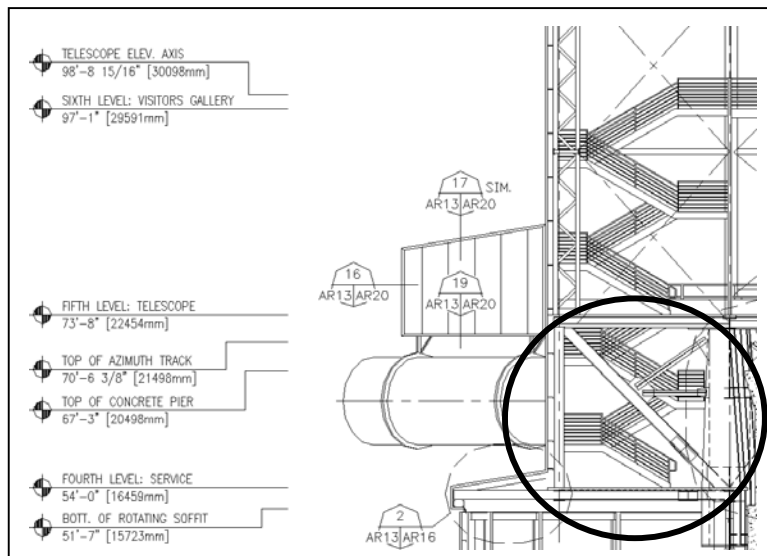

Figure 5: Location of the cooler at the telescope

- **Heat exchanger cold head to Helium**

The heat exchanger is placed around the cold end of the Stirling cooler. The flow of helium is cooled at this point.

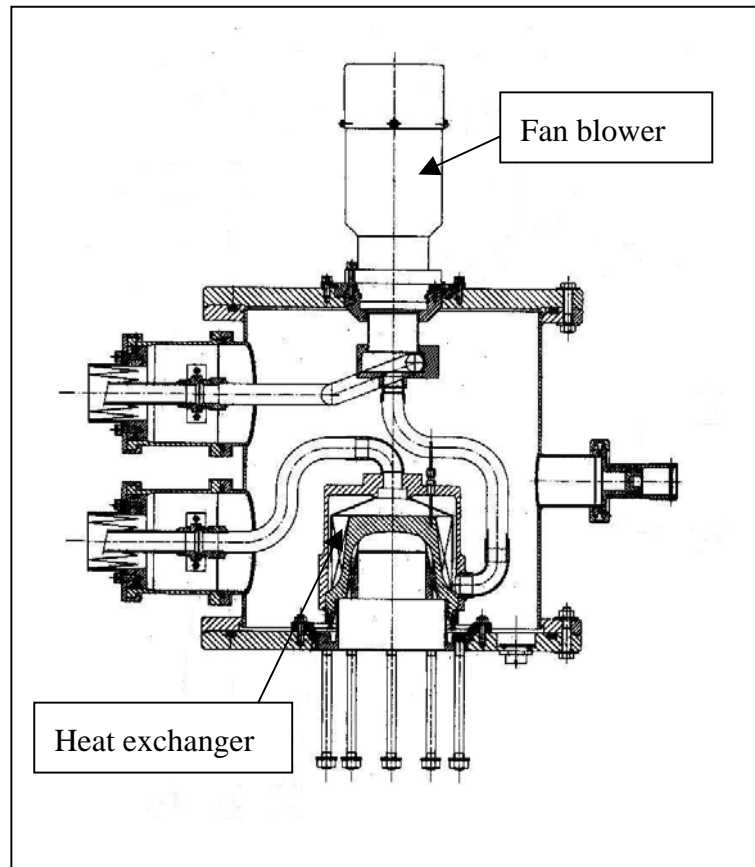

Figure 6 : Heat exchanger with fan blower on the cold end of the cooler

- **Fan blower**

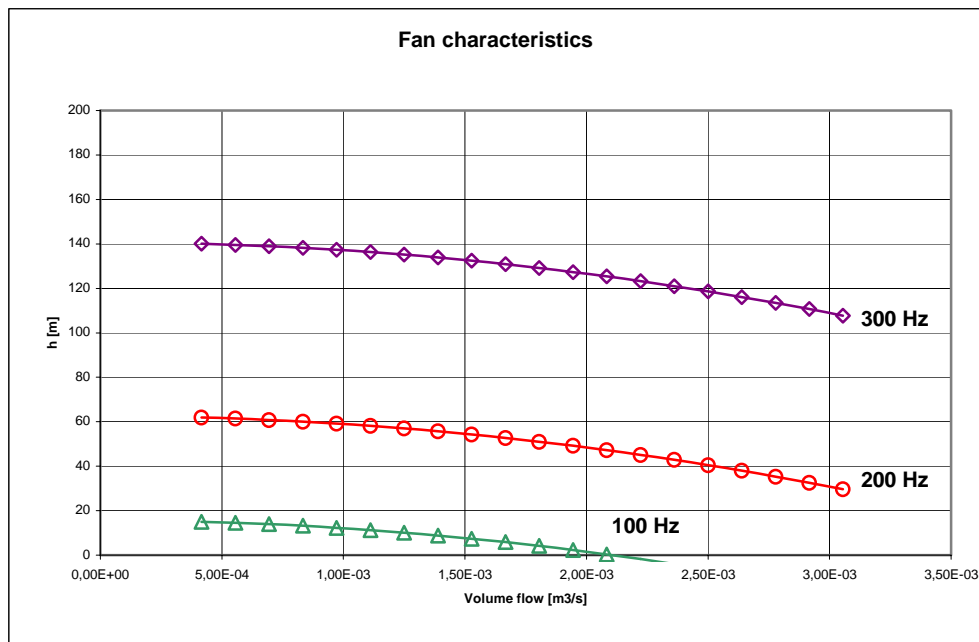

Figure 7: Characteristics of the fan blower at different speed

- **Vacuum isolated transfer lines**

Dimension length about 40 m, inner diameter 25 mm, outer diameter 85 mm, details tbd

Heat leak <1 W/m

Min. bending radius 500 mm

At the telescope we probably use a combination of fixed and flexible parts in the lines.

Routing of the lines at the telescope

The He transfer lines will go up along the inside of the outer wall of the rotating enclosure. From the rotating part of the building to the telescope there is a cable chain hanging in a loop. This loop compensates the movement of the telescope relative to the rotating building. The minimum bending radius is 500 mm. On the telescope, the lines are fixed below the mirror on the way to the instrument platform. The complete length of one line will be about 45 m. The detailed routing and dimension of these lines has to be defined and agreed with the LBTO.

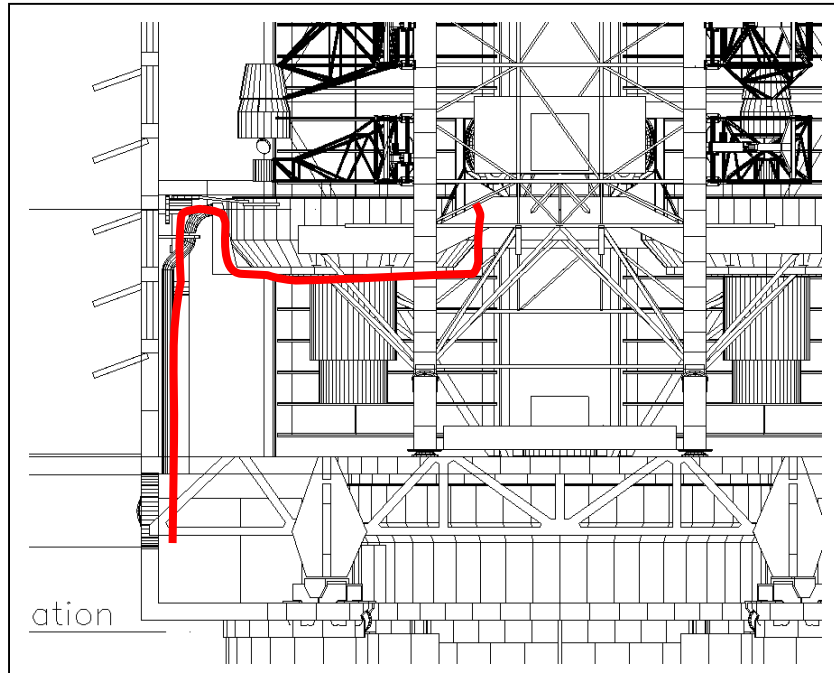

Figure 8: routing of the lines at the telescope

Line connectors/ couplings

Figure 9: transfer line connector

- **Electronic control unit**

For detailed specification see the SPC-1 manual.

- **Frequency converter**

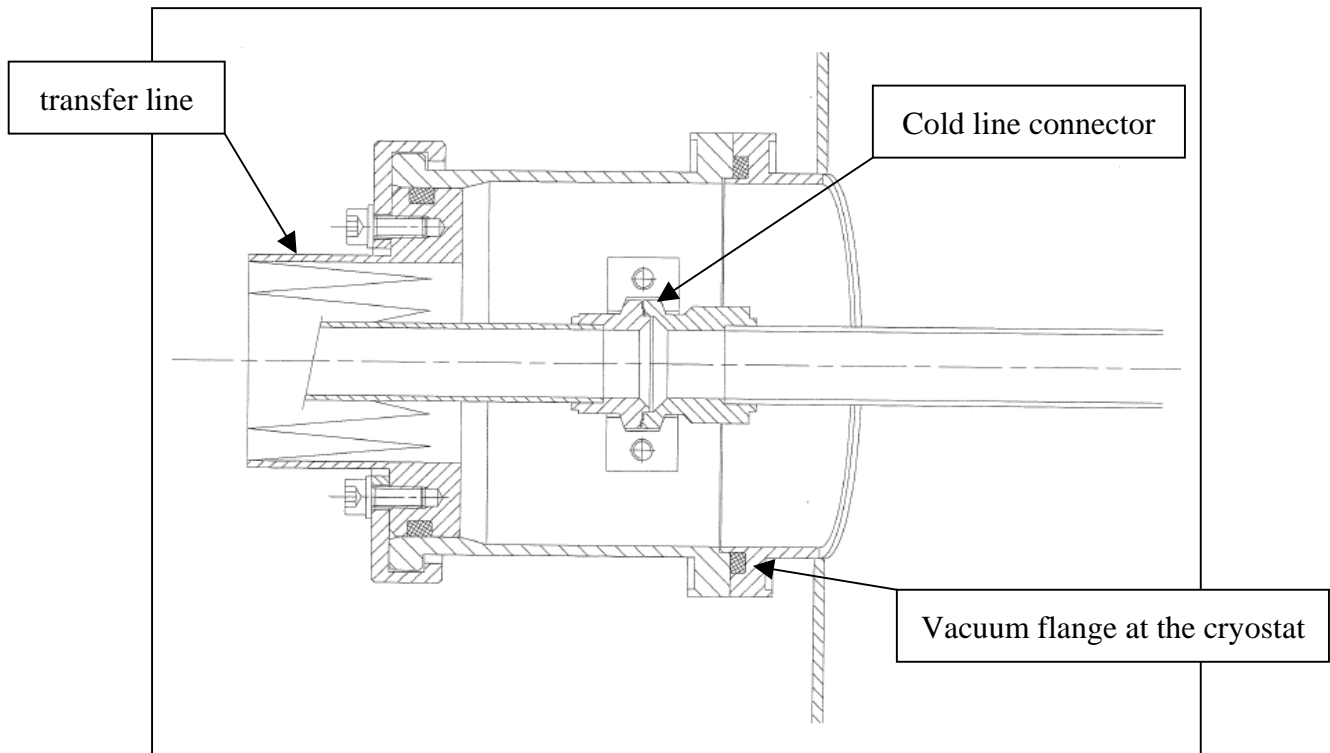
For detailed specification see the SPC-1 manual

- **Helium buffer tank**

for price reasons, we want to use standard He-tanks, which are made for a pressure up to 200 bars.

The required volume is 1200 ltr, this is the volume of two bundles of 12x50 ltr bottles.

dimensions

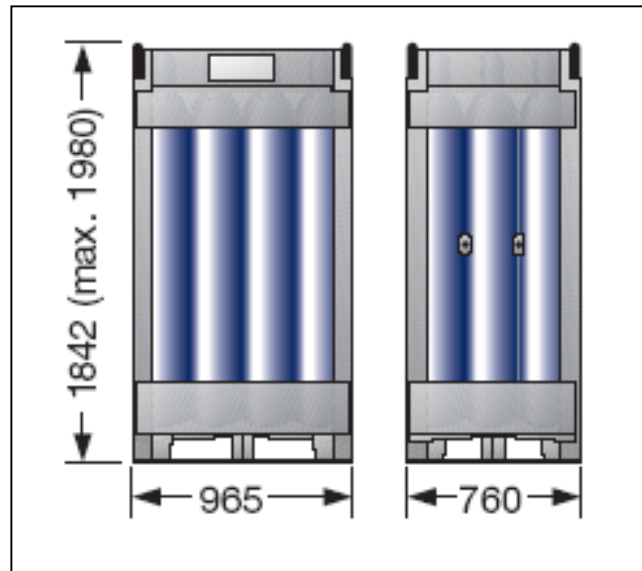

Figure 10: size of one bundle of He- bottles, left: front view, right: side view

place at the telescope

beside the cooler on the 4th level

- **Gas to air heat exchanger**

The gas to air heat exchanger is a spiral of stainless steel tube.

dimension:

Ø500, 1400 mm high

place at the telescope

beside the buffer tank

- **Thermal isolated housing**

The housing is made out of a steel frame with dismountable wall elements screwed to it. The wall elements are about 80 mm thick with a filling of rock wool and additional sound damping. One element has holes for the helium transfer lines, the power connectors and the cooling water-glycol. To remove the wasted energy inside the housing, there is an air to water heat exchanger with a cooling capacity of up to 3.500 Watts. As we have a constant coolant temperature of about 6°C, we can also use the heat exchanger to keep the cooler at working temperature if it is not running during a cold night. The installation for cooling water and electricity is fixed at this housing. It will be transported together with the cooler when we are in the integration area.

dimension:

1800 x 800 x 2100 mm

Outside temperature

-20 to +30°C

Inside temperature

6 to 30°C

7.7 Availability

- **Stirling cooler**

The cooler is a standard cooler used mainly for liquefaction of air or nitrogen. Spare parts are available from stock.

- **Heat exchanger cold head to Helium**

The heat exchanger on top of the cryocooler is specially designed for this application. It is built by Stirling. Replacement would take about 8 weeks.

- **Fan blower**

A major part is the fan blower which could be replaced in about 4 weeks.

- **Vacuum isolated transfer lines**

Transfer lines are custom made for this application, replacement will take at least 3 months

- **Helium buffer tank**

The buffer is made out of standard helium bottles. Could be replaced within 2 weeks.

- **Gas to air heat exchanger**

This is tailored for this application. Replacement takes 4 weeks.

- **Thermal isolated housing**

The housing is made for this cooler and could be replaced within 8 weeks. But if weather is not too cold the cooler could run for some time without the housing.

8 Heat exchanger

8.1 Purpose

The heat exchanger has to cool the cold structure inside the cryostat by using the cold helium gas coming from the cryogenic cooling unit described in chapter 7. It has to transport heat from conductivity, radiation, convection and electrical power dissipation away from the cold structure. In addition it is the cold structure on which all the inner components are mounted. Together with the top cover and the baffling system for the fringe tracker, the heat exchanger provides a light-tight shield around the cold optics.

8.2 Requirements

- **Thermal**

Working temperature	60 K, adjustable between 50 and 300 K No spot on the shield >100 K when operating
Long time temperature stability	about ± 1 K
Cool down time	about 24 hours, adjustable between 12 and 48 hours
Heat input	<200 W

- **Mechanical**

2 holes for the beam entry	defined in LN-MPIA-FDR-OPT-002
Mounting interface to the optical structure	defined in LN-MPIA-FDR-INT-207
Mounting interface to the fringe tracker baffling unit	defined in LN-MPIA-FDR-INT-209
Low vibrations from Helium flow	to be characterized
Low flexure from tilt	to be characterized
Holes with cover for electrical feedthroughs for	Instrument control electronic (ICE) Read out electronic (ROE)
Holes with cover for	access to filters access to inner space

- **Optical**

Light-tight enclosure for the optics
 Outside with high reflectivity (polishing or multilayer insulation)
 Inside with low reflectivity (coating with Nextel)

- **Vacuum**

Helium leak rate $<1 \cdot 10^{-8}$ mbar*l/s

8.3 Parts

- The heat exchanger, made out of a thick walled Aluminum cylinder with an Aluminum tube wrapped around
- Connectors from the heat exchanger gas line to the transfer lines defined in LN-MPIA-FDR-INT-501

8.4 Layout

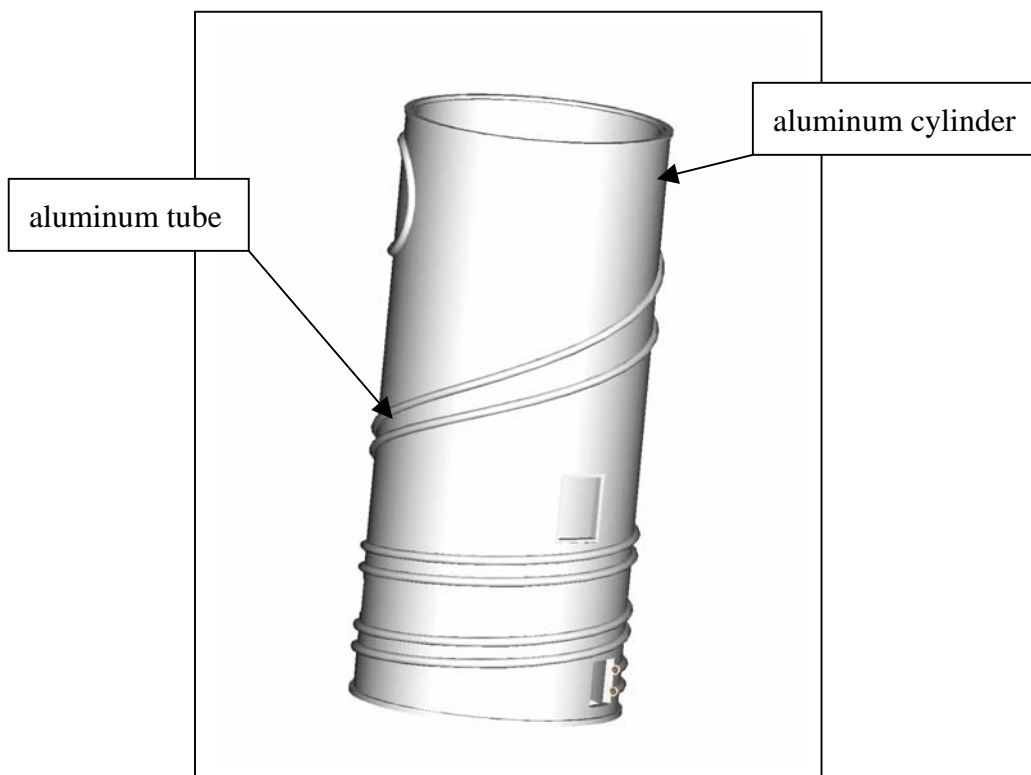

Figure 11: heat exchanger

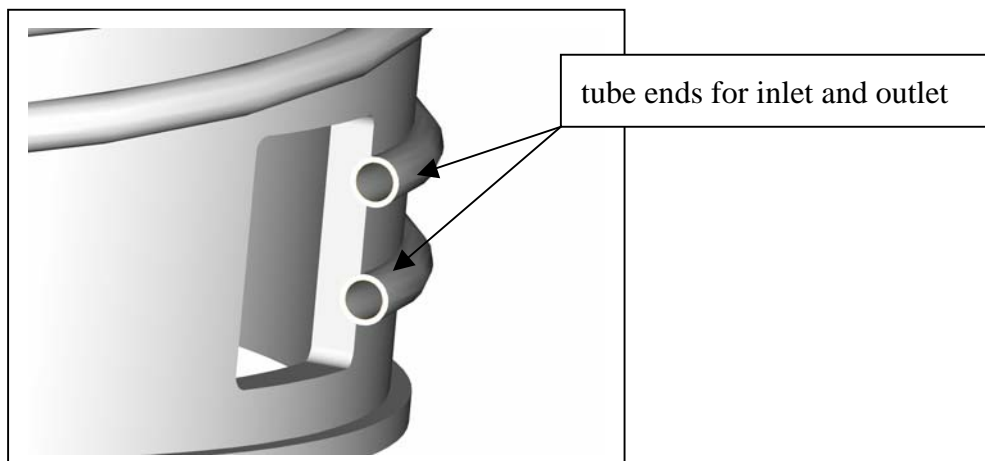

Figure 12: tube ends for inlet and outlet

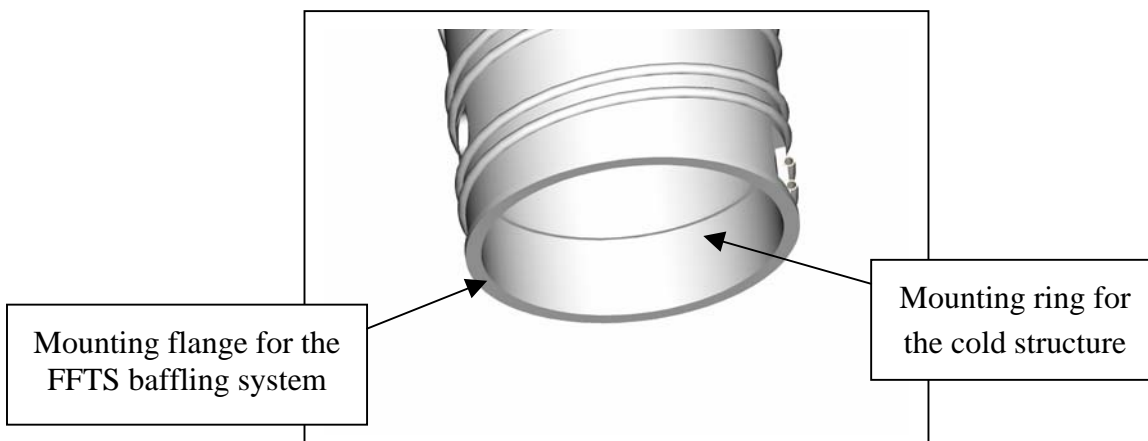

Figure 13: mounting ring for the cold structure

The heat exchanger consists of two main parts. A large cylinder from aluminum with a 10 mm deep groove with a radius of 13mm and a wrapped around tube which is embedded in this groove. For good thermal contact the tube is brazed on the cylinder in a vacuum oven. The tube around the cylinder goes up the cylinder in a spiral. Making a large loop, it changes direction and goes down the opposite direction. The inlet and outlet will be close to each other. The turn around does not have a thermal advantage but is much more convenient for the mechanical set up.

8.5 Functionality

A flow of cold helium gas will enter the heat exchanger at the supply side and flow through a tube in a turbulent flow. There will be a thermal exchange between the wall of the tube and the cold gas. The temperature of the gas will increase and leave the heat exchanger at the return side.

The connectors to the transfer line are vacuum isolated and warm on the outside. The inside tube transports the cold helium gas with low heat input from the transfer lines to the heat exchanger.

Calculation of the efficiency of the heat exchanger were made by Stirling. It can be found in LN-MPIA-FDR-CRY-002-APP-A.

The heat exchanger is also used for warming up and cooling down of the instrument using the cold or warm gas from the cooler.

8.6 Specification

Aluminum cylinder dimensions	ID 670 mm, OD 718 mm, length 1630 mm
Length of the helium tube	15 m
Helium tube inner diameter	20 mm
Material	aluminum
Entrance temperature	60
Exit temperature	<64
Bending due to tilt	tbd
Cooling capacity	>200 W

8.7 Availability

The heat exchanger and couplings are custom made parts tailored for this instrument. Delivery time

- Heat exchanger 6 month
- Couplings 4 weeks

9 Vacuum can

9.1 Purpose

The vacuum can is the enclosure of the heat exchanger with the cold optics and the detector. The vacuum gives a clean environment for the cold optics and protects it from condensing gas. In addition, heat transfer from convection is suppressed. The vacuum can needs at least the same mechanical stability as the heat exchanger, because every flexure of the vacuum can may results in flexure of the cold optics.

The vacuum system is very similar to the LUCIFER¹ vacuum system, since the size is comparable and in order to use common components for simple logistics of spare parts and maintenance at the observatory.

9.2 Requirement

Vacuum when instrument is warm	$<1 * 10^{-4}$ mbar
Vacuum when instrument is cold	$<1 * 10^{-5}$ mbar
Leak rate	$<1 * 10^{-8}$ mbar*liter /sec
Hold time of the vacuum by cryogenic pumping	>3 month

9.3 Parts

No	Name	Manufacturer	Type
1	Scroll pump	BOC Edwards GmbH	GVSP30
2	Pressure switch	Leybold Vakuum GmbH	PS115
3	Solenoid valve	BOC Edwards GmbH	LCPV25EKA
4	Turbo molecular pump	Pfeiffer Vacuum GmbH	TMH 400 M
5	Vacuum gauge	Pfeiffer Vacuum GmbH	PKR 251
6	Vacuum safety valve	Custom made	
7	Vacuum chamber	Custom made	
8	Vent valve	BOC Edwards GmbH	IPVA10EK

Table 1: Parts of the vacuum system

¹ LUCIFER is an infrared imager spectrograph for the LBT. The vacuum system has been built by MPIA.

9.4 Layout

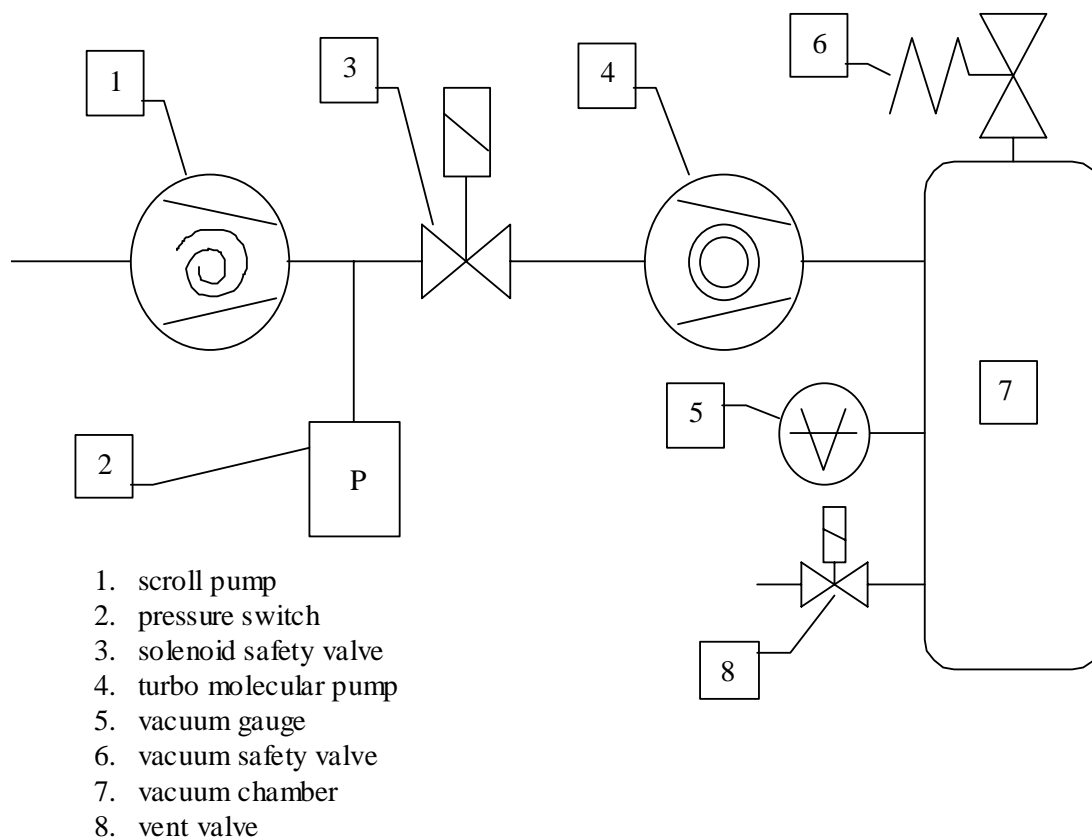

Figure 14: Schematic diagram of the vacuum system

9.5 Functionality

The scroll pump (1) gives an oil free roughing vacuum. The roughing line is controlled by a pressure switch (2), which in case of pressure increase closes the solenoid safety valve (3). The turbo molecular pump (4) is able to reach the required vacuum of the cryostat. The solenoid valve is also used to close up the instrument vacuum when the instrument is cold which in this case includes the volume of the turbo molecular pump. Vacuum is measured directly at the chamber (7) with a standard vacuum gauge (5). There will be a second gauge for redundancy. In case of overpressure from a leak in combination with warming up we use a vacuum safety valve which opens when pressure inside the chamber is slightly above ambient. For venting the chamber we use a solenoid valve (8) which is locked as long as the instrument is cold. To this valve a line with nitrogen gas could be connected.

The vacuum inside the cryostat is maintained by a cooled package of charcoal (“getter”). This package has a heater to regenerate it when it is saturated. During regeneration, the cooler will be switched off and the vacuum pumps have to run.

9.6 Specification

- Vacuum vessel

size $\varnothing 794$ mm x 2355 mm high
 material stainless steel
 seals Viton O-rings

- Flanges on the can

- 2 entrance windows
 - turbomolecular pump
 - He in/out
 - vacuum gauge
 - flange for control electronics (upper part)
 - flange for control electronics (lower part)
 - flange for ROE FFTS
 - flange for ROE science detector
 - flange for filter exchange
 - flange for additional access
 - service window (bottom)
- DN160 ISO-K
 2 x DN 100 ISO-K
 2 x DN 25 KF
 special rectangular flange
 special rectangular flange

 2 x DN 100

- Vacuum safety valve

Size $\varnothing 130$
 Leak rate $<1 \cdot 10^{-8}$ mbar*l/sec
 Opening pressure 150 mbar above ambient

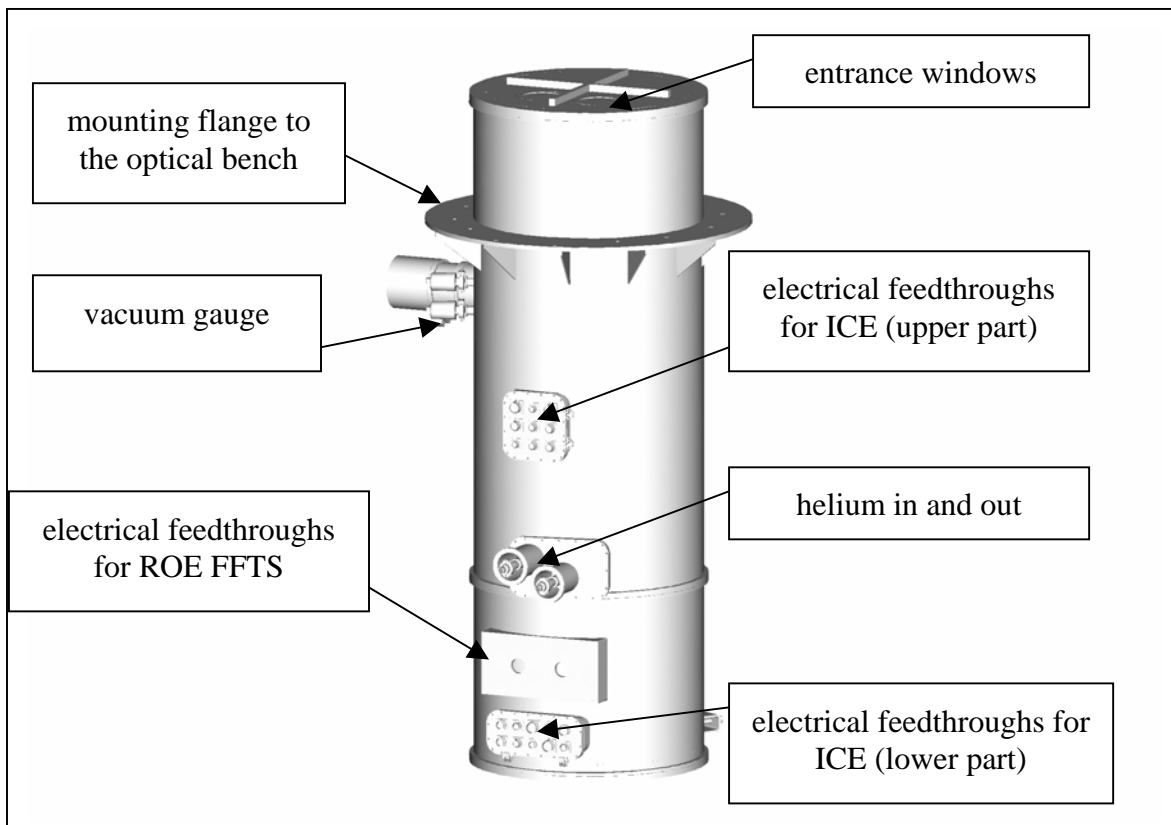

Figure 15: View of the cryostat vacuum vessel

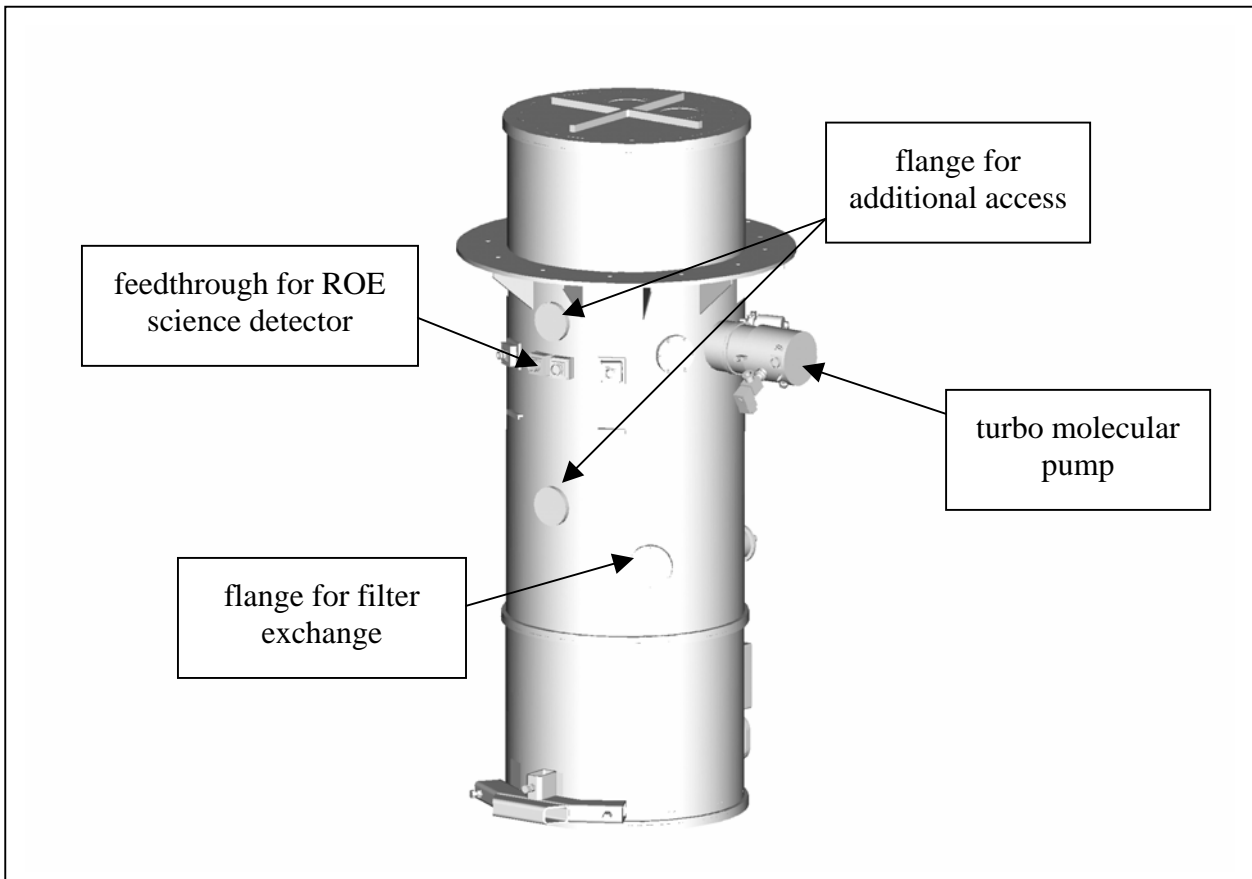

Figure 16: View of the cryostat vacuum vessel

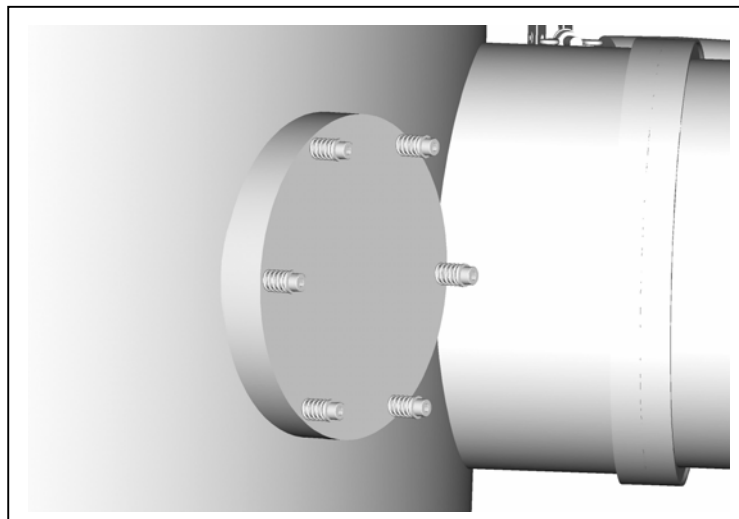

Figure 17: Spring loaded overpressure safety valve

The detailed specification of the standard components such as pumps or vacuum gauges could be found in the manuals.

9.7 Availability

All standard components of the vacuum system have short delivery times.

For O-rings there will be spares, at least 2 for each flange

The vacuum can has a delivery time of about 5 months

10 Spacers

10.1 Purpose

The cryostat is a unit with a cold inner structure and a housing at ambient temperature. The connection between the warm and the cold structure has to have high mechanical stability and low thermal conductivity.

10.2 Requirements

Low bending from tilt of the cryostat tbd

Has to allow thermal shrinking in axial and radial direction.

Heat input from warm to cold below 10 W

10.3 Layout

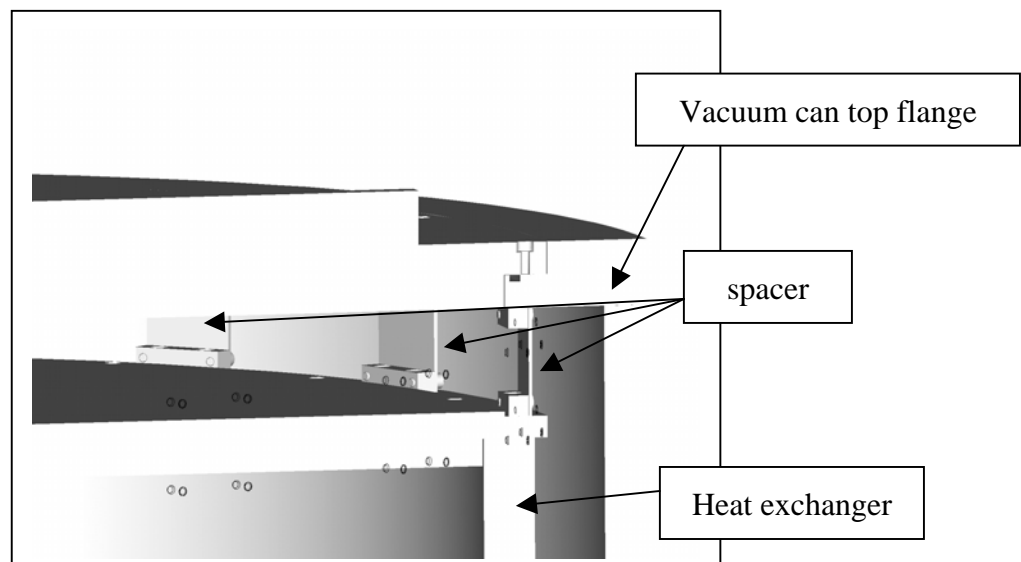

Figure 18: Spacer at the top flange of the cryostat

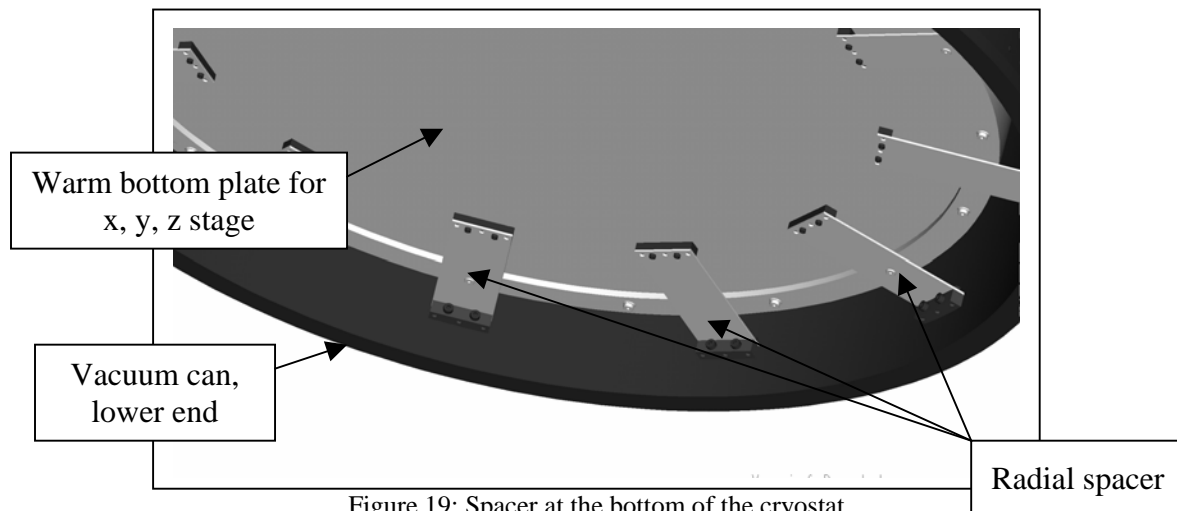

Figure 19: Spacer at the bottom of the cryostat

10.4 Functionality

The cold heat exchanger is fixed inside the vacuum can by using spacers from fiber enforced plastics. This material has high mechanical strength and low heat conductivity. At the upper side of the cryostat (where the windows are), the spacers allow thermal shrinking of the heat exchanger in the radial direction but fix the heat exchanger in the axial direction. At the other end of the heat exchanger, the warm X/Y/Z stage is mounted. Here, we have spacers which allow a shrinking in axial direction but fix the heat exchanger in radial direction.

10.5 Specification

Dimensions	tbd
Bending of the spacers due to tilt	tbd
Heat conductivity	tbd

10.6 Availability

Spacers are specially made for this cryostat. From each type there will be spares. Manufacturing will take about 2 weeks.

11 Mounting and dismounting of the cryostat

11.1 Purpose

The cryostat is a complex unit, and has to be assembled and mounted at the telescope. For repair or technical changes, it may be necessary to dismount the instrument from the telescope. It could also happen that the instrument has to be set up in an integration area. For tests at the integration area, a working cryostat is necessary. As we have fixed the transfer lines to the telescope and have the cooler in the rotating part of the telescope, the cooler and the lines have to be moved.

11.2 Requirements

It is required to have access to the built in optics, mechanics and electronics. This implies that disassembly of the cryostat should be straightforward. Access should be as easy as possible. The optics should not be misaligned after disassembly and reassembly.

11.3 Parts

The cryostat consists of the previously mentioned parts:

- Cooling unit with helium transfer lines
- Heat exchanger
- Vacuum can
- Spacers

Additionally, we have built in parts which are:

- Structure with optics and detector (see AD2: LN-MPIA-FDR-CRY-001)
- Secondary mirror (see AD2: LN-MPIA-FDR-CRY-001)
- FFTS with baffling system and warm x/y/z stage (see AD3: LN-KOELN-FDR-CRY-001)

11.4 Layout

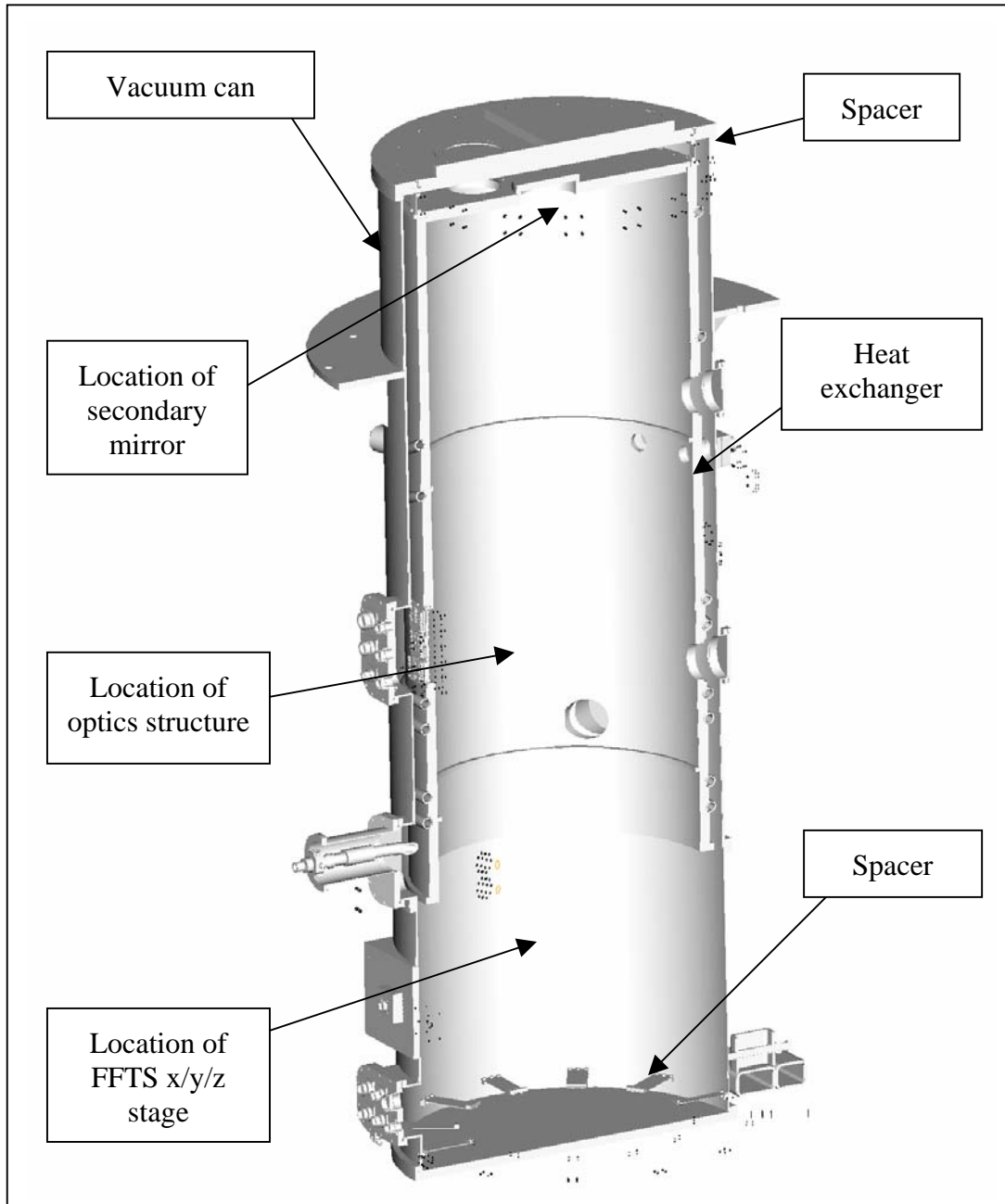
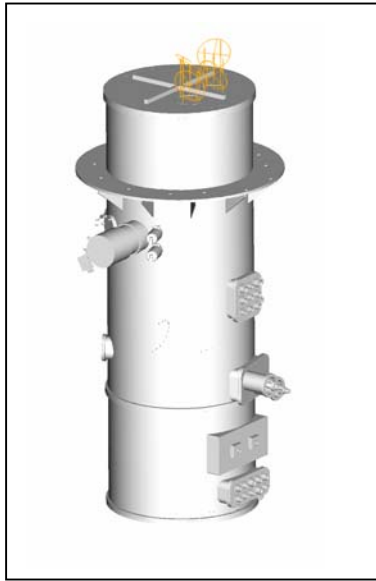
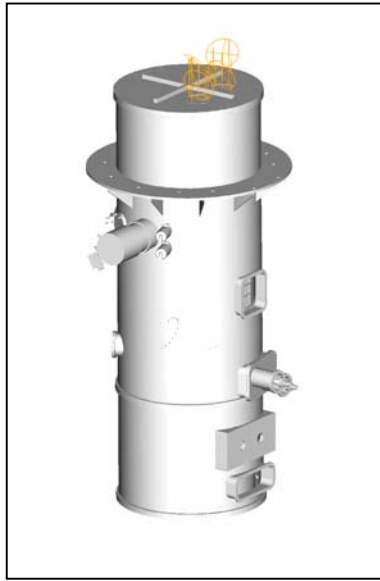

Figure 20: vacuum can with built-in heat exchanger

Figure 21: disassembly of the cryostat in a sequence of pictures



cryostat completely assembled



electrical feedthroughs off

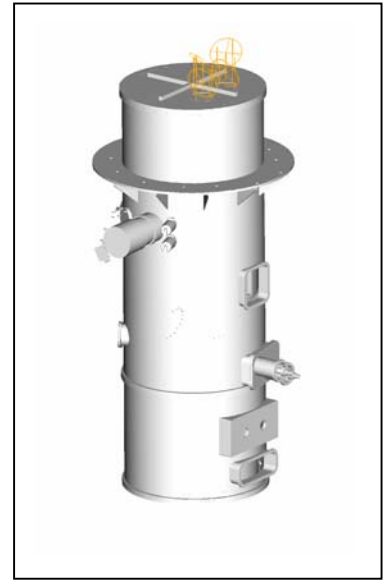

thermal coupling of the cables
dismounted

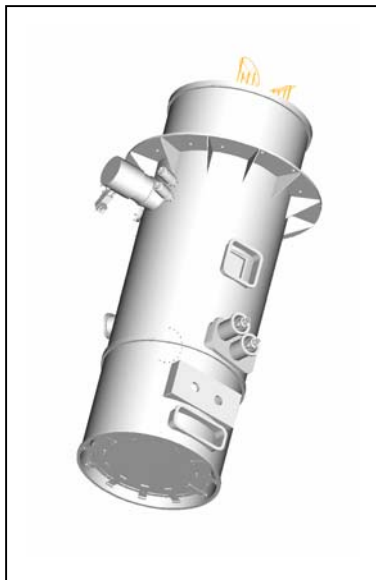

bottom plate removed

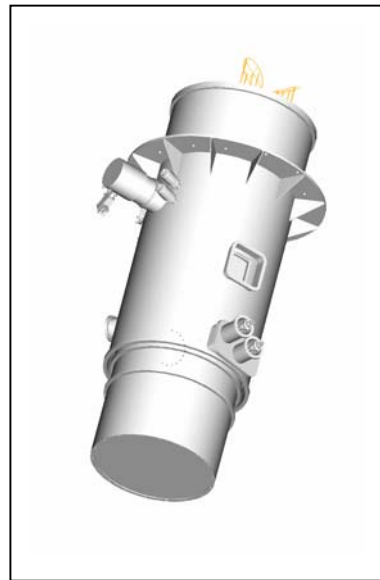

lower part of the vacuum can
removed

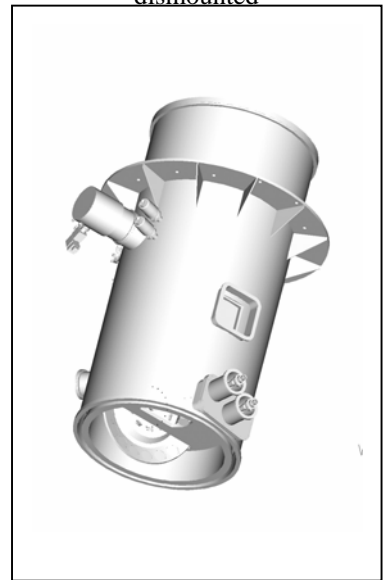

FFTS removed



inner structure

11.5 Functionality

The initial status for the disassembly of the cryostat is:

- Cryostat is warm
- Vented with dry nitrogen to ambient pressure

The disassembly is shown in Figure 21: disassembly of the cryostat in a sequence of pictures. Referring to this sequence the following steps have to be done:

- Remove all connectors, cables, and electronics
- Take out the thermal coupling of the cables and remove the internal cables up to the patch board
- Remove the bottom plate and disconnect the spacers
- Remove the lower part of the vacuum can
- Remove the FFTS together with the x, y, z stage and the baffling
- Now you have access to the inner structure, where the cold optics and the detector are mounted.
- The inner structure can be lowered out of the cryostat

Removal of the heat exchanger from the vacuum can is also possible but should not be necessary on site.

---oOo---