

# LINC-NIRVANA

The **L**BT **I**nterferometric **C**amera and  
**N**ear-**I**nfra**R**ed / **V**isible **A**daptive  
**i**nterferometer for **A**stronomy

A collaborative project of the MPIA Heidelberg, INAF-Arcetri,  
Universität zu Köln, and MPIfR Bonn

<http://www.mpia.de/LINC>

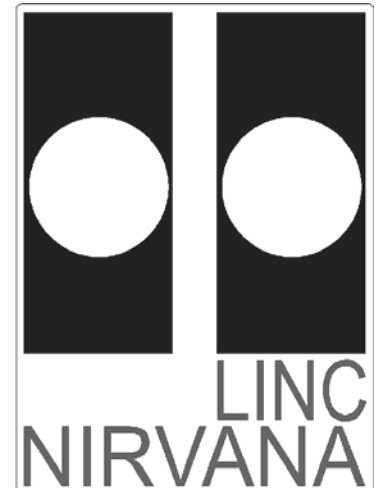

## LINC-NIRVANA

-

### **Detector Front End Electronics Wiring and Schematics**

Doc. No.      LN-MPIA-TN-ELEC-NNN  
Short Title    DFE  
Issue          0.1  
Date            02 September 2004

Prepared	<u>U. Mall</u>	<u>02 september 2004</u>	
	Name	Date	Signature
Approved	.....		
	Name	Date	Signature
Released	.....		
	Name	Date	Signature

## Document Change Record

Issue	Date	Section/ Paragraph Affected	Reasons / Remarks
0.1	02 Sept. 2004	All	new document

## TABLE OF CONTENTS

<b>1</b>	<b>Scope</b> .....	<b>5</b>
<b>2</b>	<b>Applicable documents</b> .....	<b>5</b>
<b>3</b>	<b>Acronyms and abbreviations</b> .....	<b>5</b>
<b>4</b>	<b>Introduction</b> .....	<b>5</b>
<b>5</b>	<b>Functions</b> .....	<b>5</b>
<b>6</b>	<b>Power Supply</b> .....	<b>5</b>
6.1	Cable 1 from DACE to Biasbox.....	6
6.2	Cable 2 from biasbox to clockbox.....	7
<b>7</b>	<b>Biasbox</b> .....	<b>8</b>
7.1	Biasbox Power Wiring.....	9
7.2	Bias Wiring.....	9
7.3	Biasboard Schematics.....	11
<b>8</b>	<b>Clockbox</b> .....	<b>16</b>
8.1	Clockbox Power Wiring.....	16
8.2	Clock Signal Cabling.....	16
8.3	Clockbox Schematics.....	21
<b>9</b>	<b>Dewar and Fanoutboard</b> .....	<b>26</b>
9.1	Clock Cabling in the Dewar.....	27
9.2	Bias Cabling in the Dewar.....	27
9.3	Video Cabling in the Dewar.....	28
9.4	Video Cabling from Dewar to DACE.....	31

## LIST OF TABLES

## LIST OF FIGURES

Figure 1	Power Supply Cabling.....	5
Figure 2	Power outlet at the DACE.....	6
Figure 3	Cable 1 from DACE to Biasbox.....	6
Figure 4	Power input at the biasbox.....	7
Figure 5	Power outlet at the biasbox.....	7
Figure 6	Cable 2 from biasbox to clockbox.....	7

---

Figure 7 Power input at the clockbox .....	8
Figure 8 Biasbox overview .....	8
Figure 9 Biasbox cable 3, 4 and 5 .....	9
Figure 10 Biasbox cable 6.....	10
Figure 11 Clockbox overview.....	16
Figure 12 Clockbox cable 7 and 8 .....	16
Figure 13 Clock outlet at DACE.....	17
Figure 14 Clock extension cable.....	18
Figure 15 Clockbox cable 9 .....	19
Figure 16 Clockbox cable 10 .....	20
Figure 17 Fanoutboard cabling overview .....	26
Figure 18 Clock cabling in the dewar .....	27
Figure 19 Bias cabling in the dewar.....	28
Figure 20 Video 1 cabling in the dewar.....	29
Figure 21 Video 2 cabling in the dewar.....	31

## 1 Scope

This document describes the Detector Frontend Electronics.

## 2 Applicable documents

No.	Title	Number & Issue

## 3 Acronyms and abbreviations

DFE	Detector Frontend Electronics
ROE	ReadOut Electronics
SW	Software

## 4 Introduction

The Detector Frontend Electronics interfaces the HAWAII2 detector with the ReadOut Electronics.

## 5 Functions

The DFE consists of four components:

- Power Supply
- Biasbox
- Clockbox
- Fanoutboard

## 6 Power Supply

The Power Supply is linear regulated and located in the DACE. It delivers +- 8 Volts / 2 Amps.

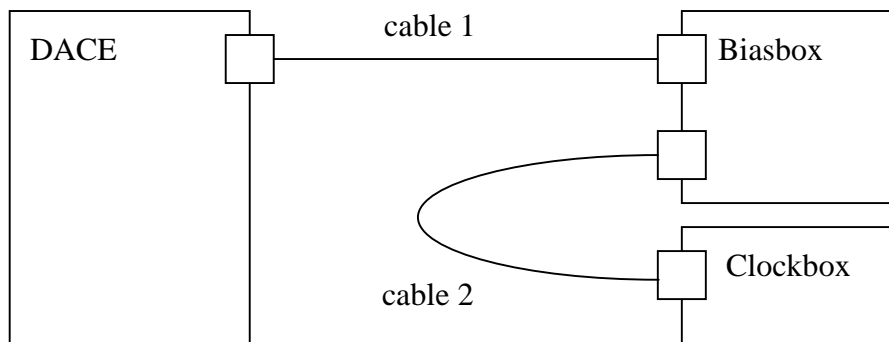

Figure 1 Power Supply Cabling

## 6.1 Cable 1 from DACE to Biasbox

The power comes out of a PT02SE14-12S connector at the DACE with the following assignment:

PT02SE14-12S	
A	+Sense 1
B	-Sense 2
C	+Sense 2
D	-Sense 2
J	+U 1
K	-U 1
L	+U 2
M	-U 2

Figure 2 Power outlet at the DACE

Cable 1 is a simple 8x2x0,5 (AWG20) twisted pair extension cable that connects the power supply to the biasbox.

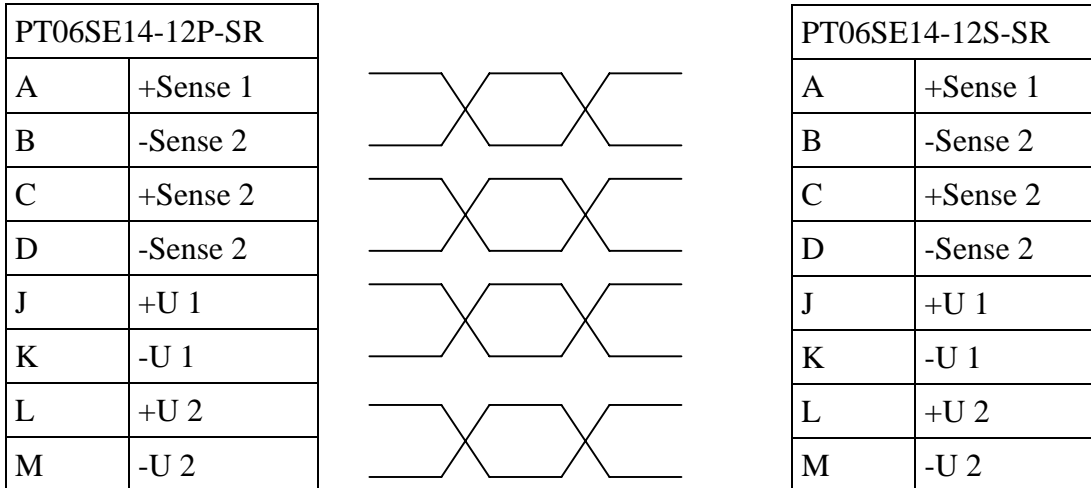

Figure 3 Cable 1 from DACE to Biasbox

Due to the nature of an extension cable the power input at the biasbox has the same assignment as the power outlet at the DACE. Note that the power input has pins.

PT02SE14-12P	
A	+Sense 1
B	-Sense 2

C	+Sense 2
D	-Sense 2
J	+U 1
K	-U 1
L	+U 2
M	-U 2

Figure 4 Power input at the biasbox

## 6.2 Cable 2 from biasbox to clockbox

The biasbox has a second connector. This is the power outlet to the clockbox as well as the clock supply voltage generated by the biasboard. It uses a PT02SE14-5S receptacle with the following assignment:

PT02SE14-5S	
A	+U 1
B	-U 1
C	+Vclock
D	-Vclock

Figure 5 Power outlet at the biasbox

There is another extension cable to connect to the clockbox:

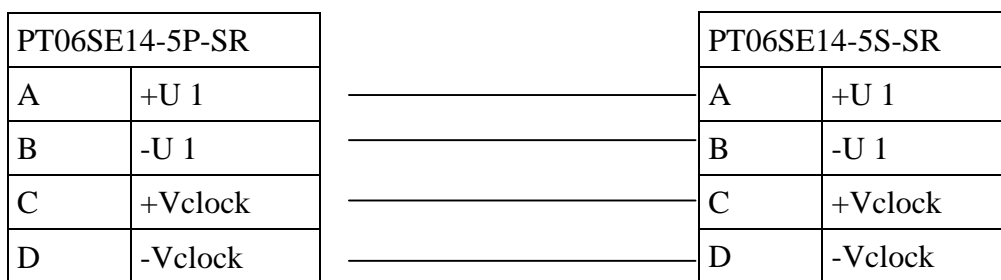

Figure 6 Cable 2 from biasbox to clockbox

Last but not least there is the power input at the clockbox. Surprisingly it has an PT02SE14-5P receptacle with the following assignment:

PT02SE14-5P	
A	+U 1
B	-U 1
C	+Vclock

D	-Vclock
---	---------

Figure 7 Power input at the clockbox

## 7 Biasbox

The biasboard is mounted in an aluminum box. Together they build the biasbox. The biasbox has one power input connector, one power output connector and a third connector that feeds the biases to the fanoutboard.

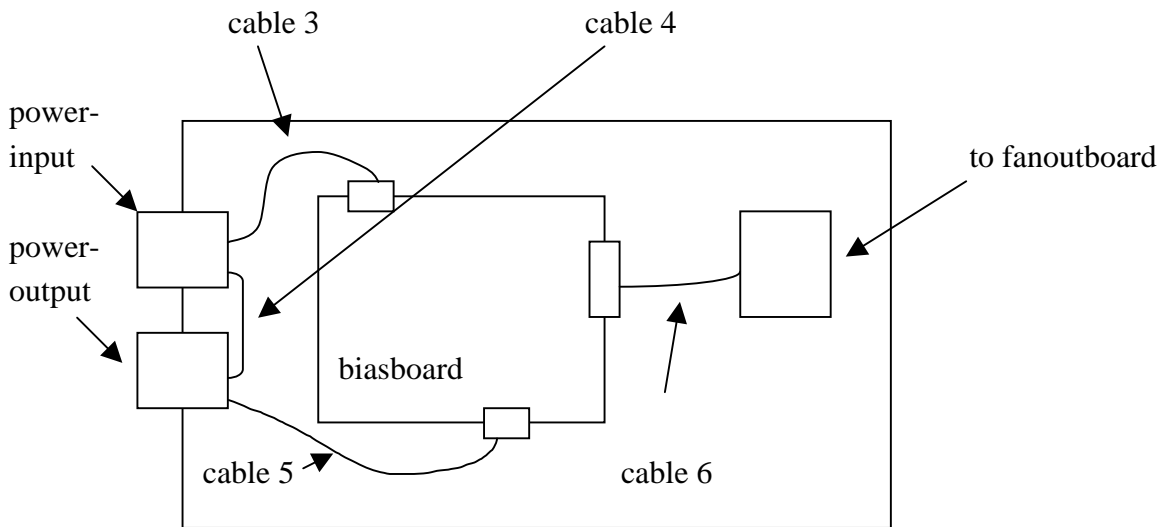

Figure 8 Biasbox overview

### 7.1 Biasbox Power Wiring

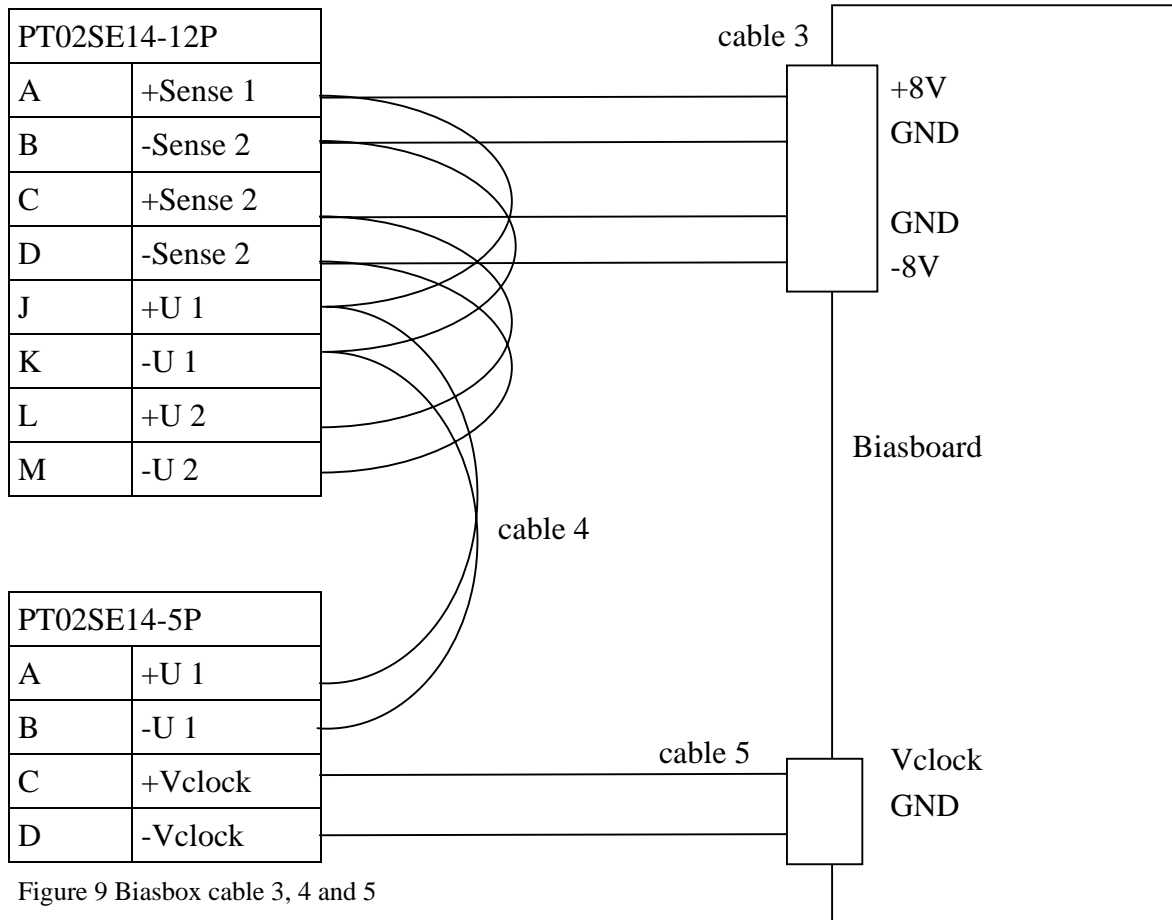

Figure 9 Biasbox cable 3, 4 and 5

### 7.2 Bias Wiring

HARMIK PuS 50S		PT06SE16-26S
11	Dsub	A
20	GND	B
21	GND	C
2	VDDA	D
4	VLOAD2	E
22	GND	F

26	GND	G
10	ext_bias	H
27	GND	J
28	GND	K
1	VDD	c
14	+VCC	L
15	+VCC	M
8	Biasgate	N
12	Drain	P
29	GND	R
30	GND	S
5	VLOAD3	T
49	GND	U
50	GND	V
7	VReset	W
9	Biaspower	X
3	VLOAD1	Y
6	VLOAD4	Z
16	-VCC	a
17	-VCC	b

Figure 10 Biasbox cable 6

### 7.3 Biasboard Schematics

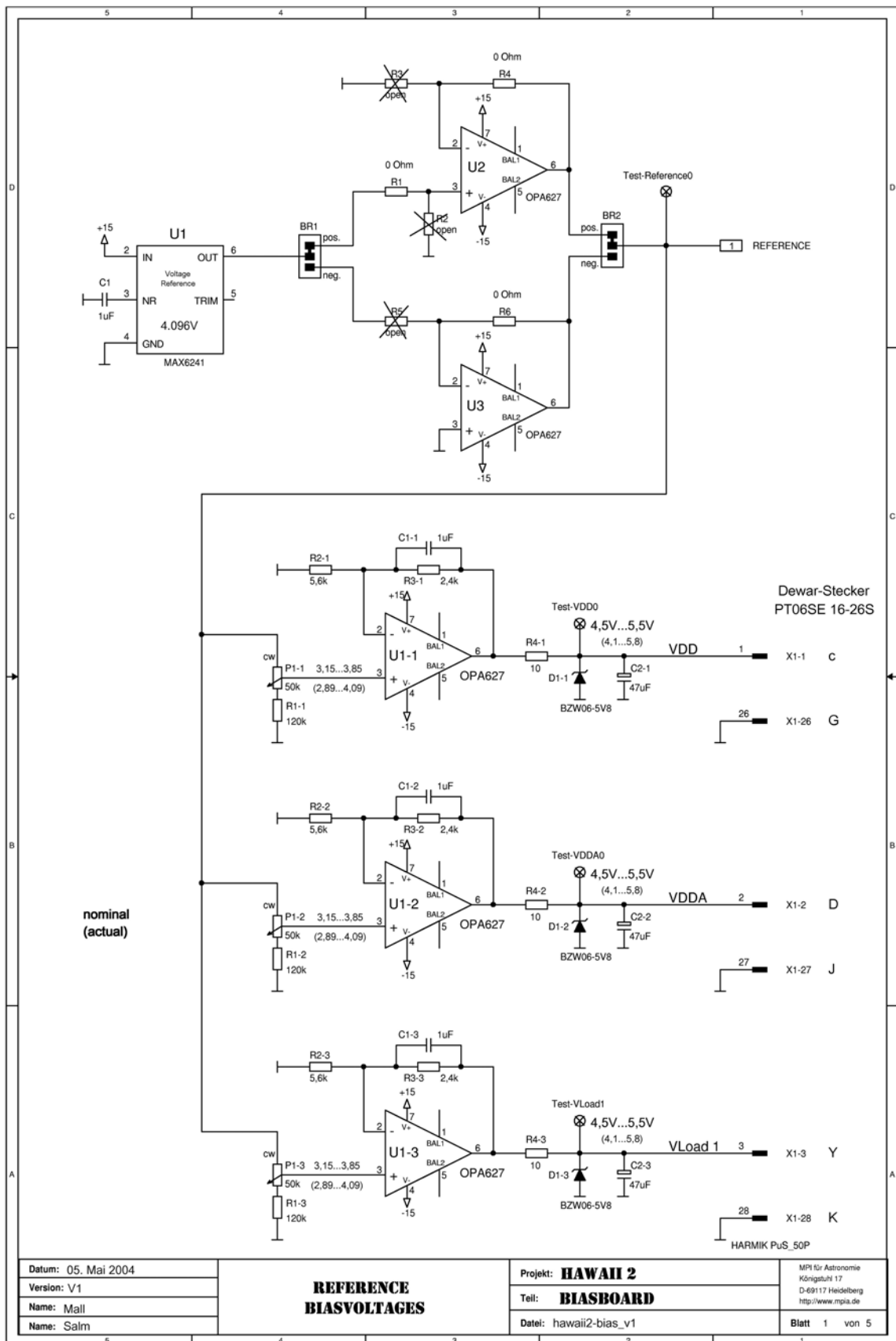

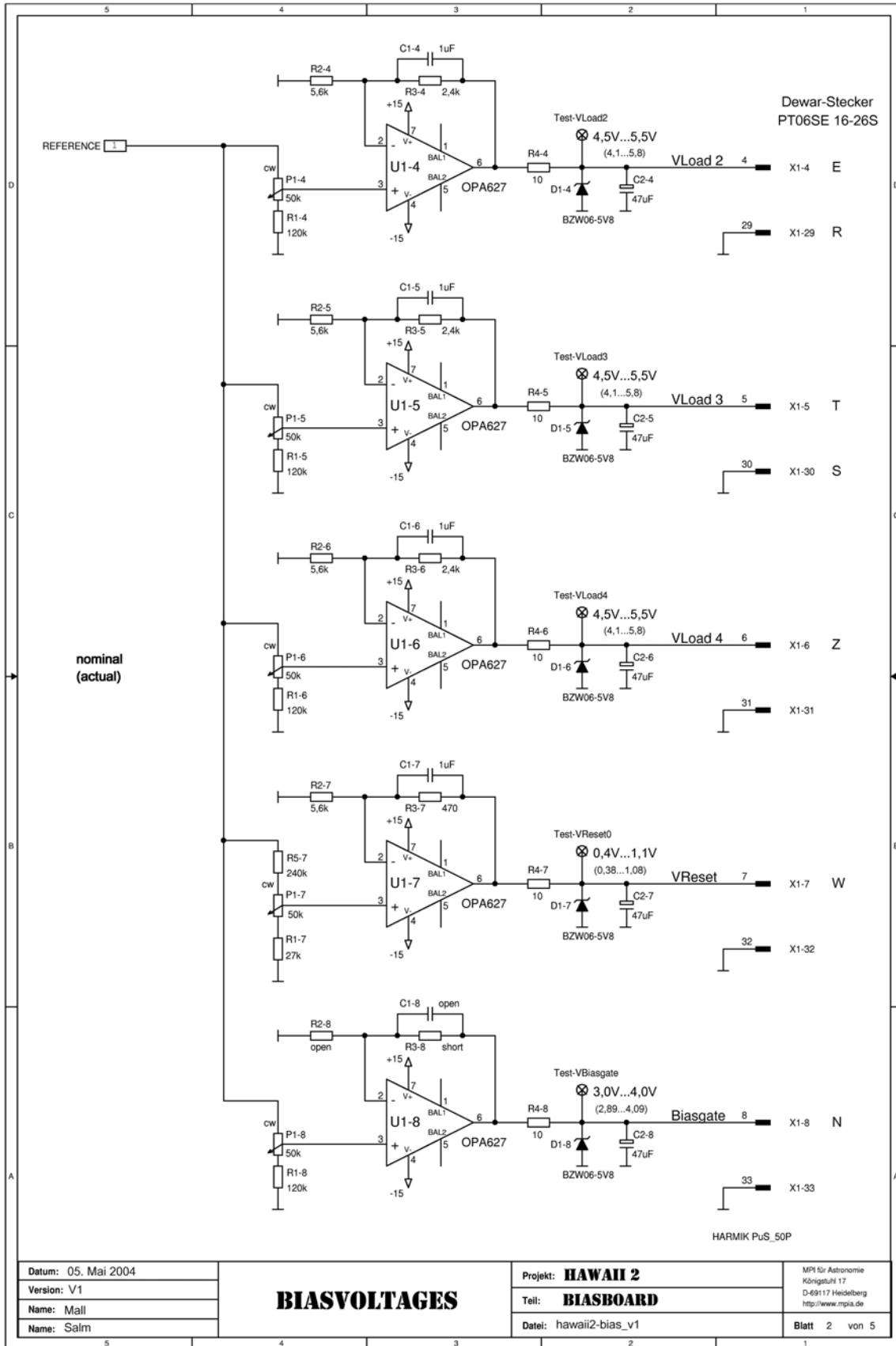

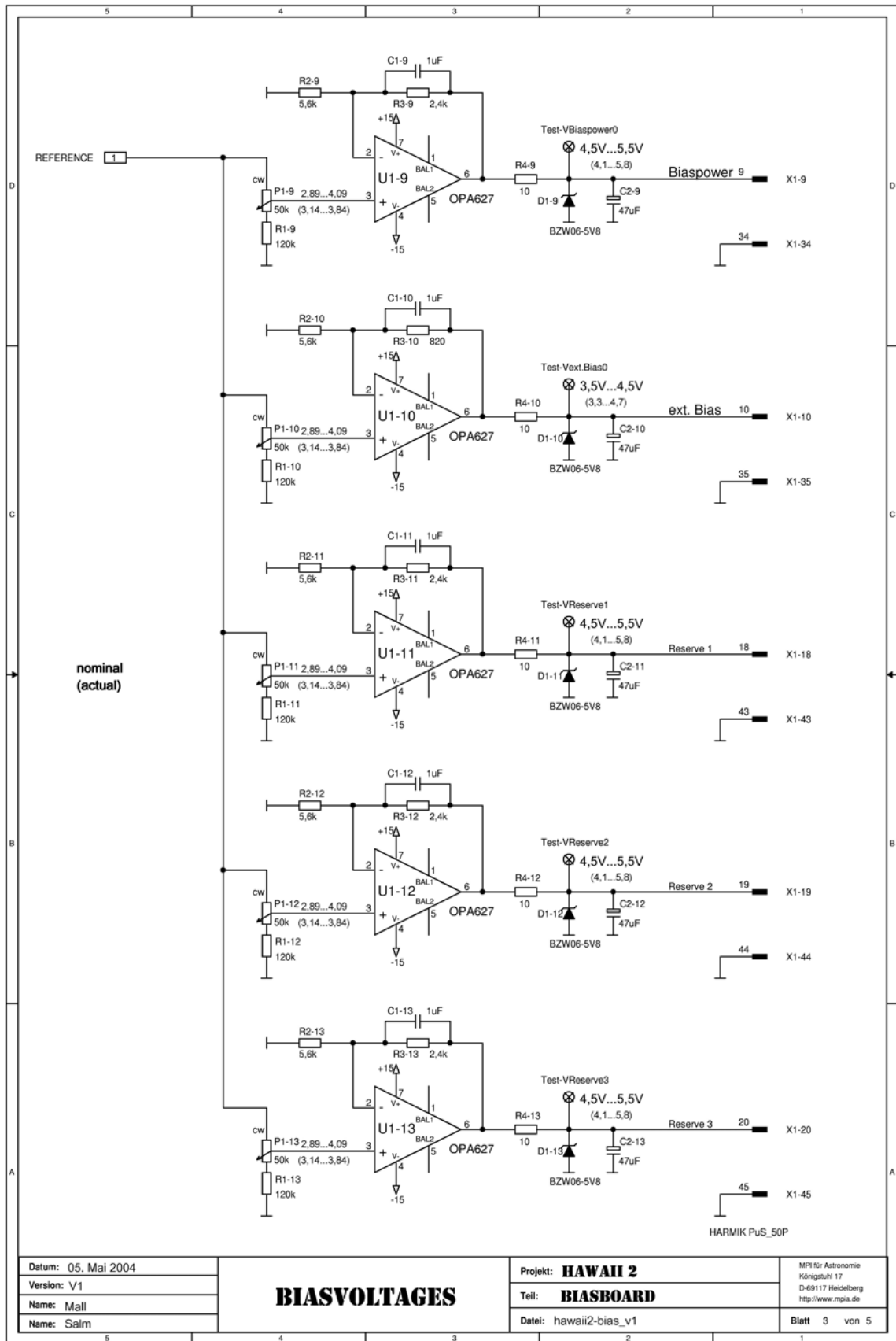

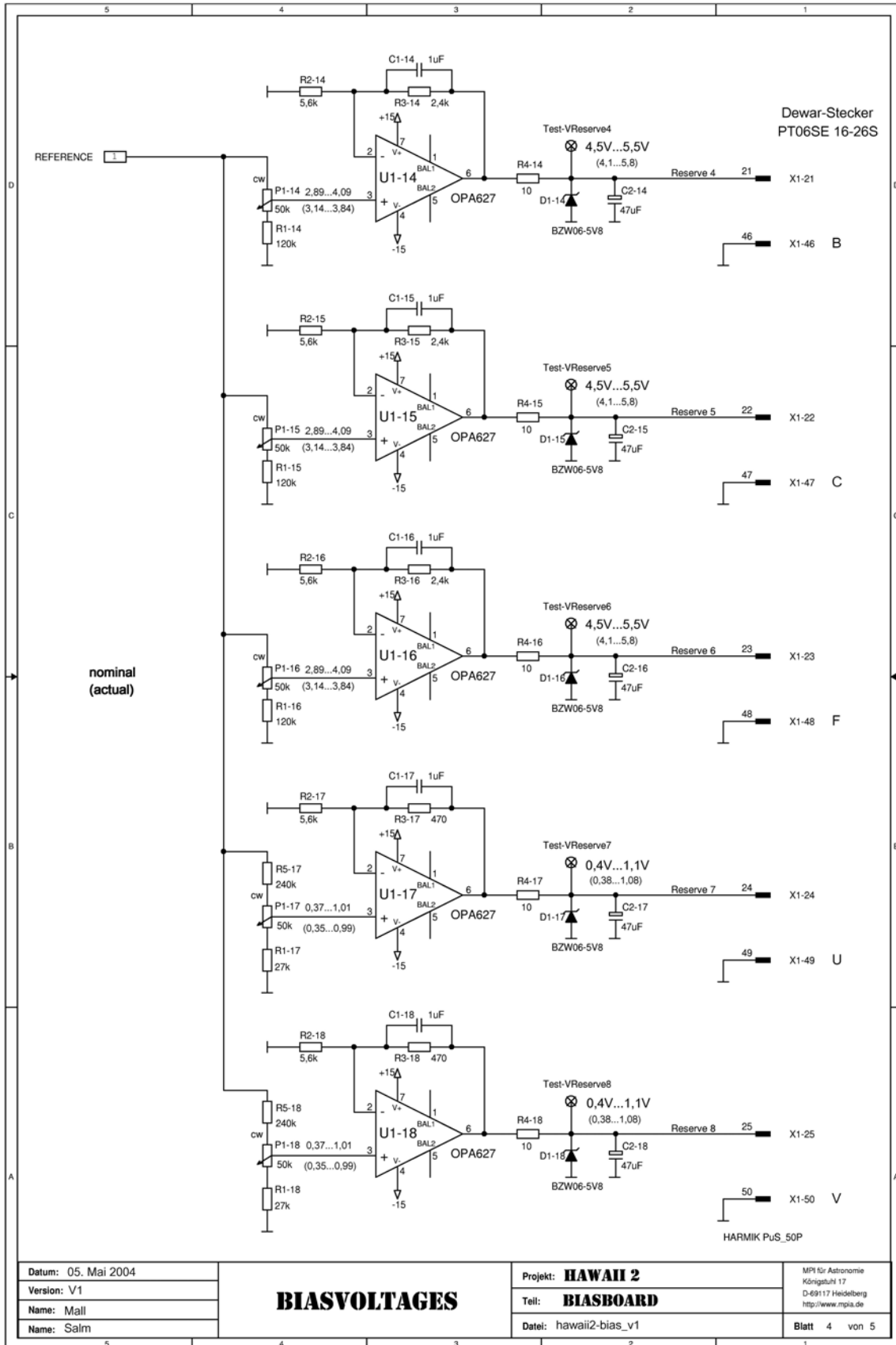

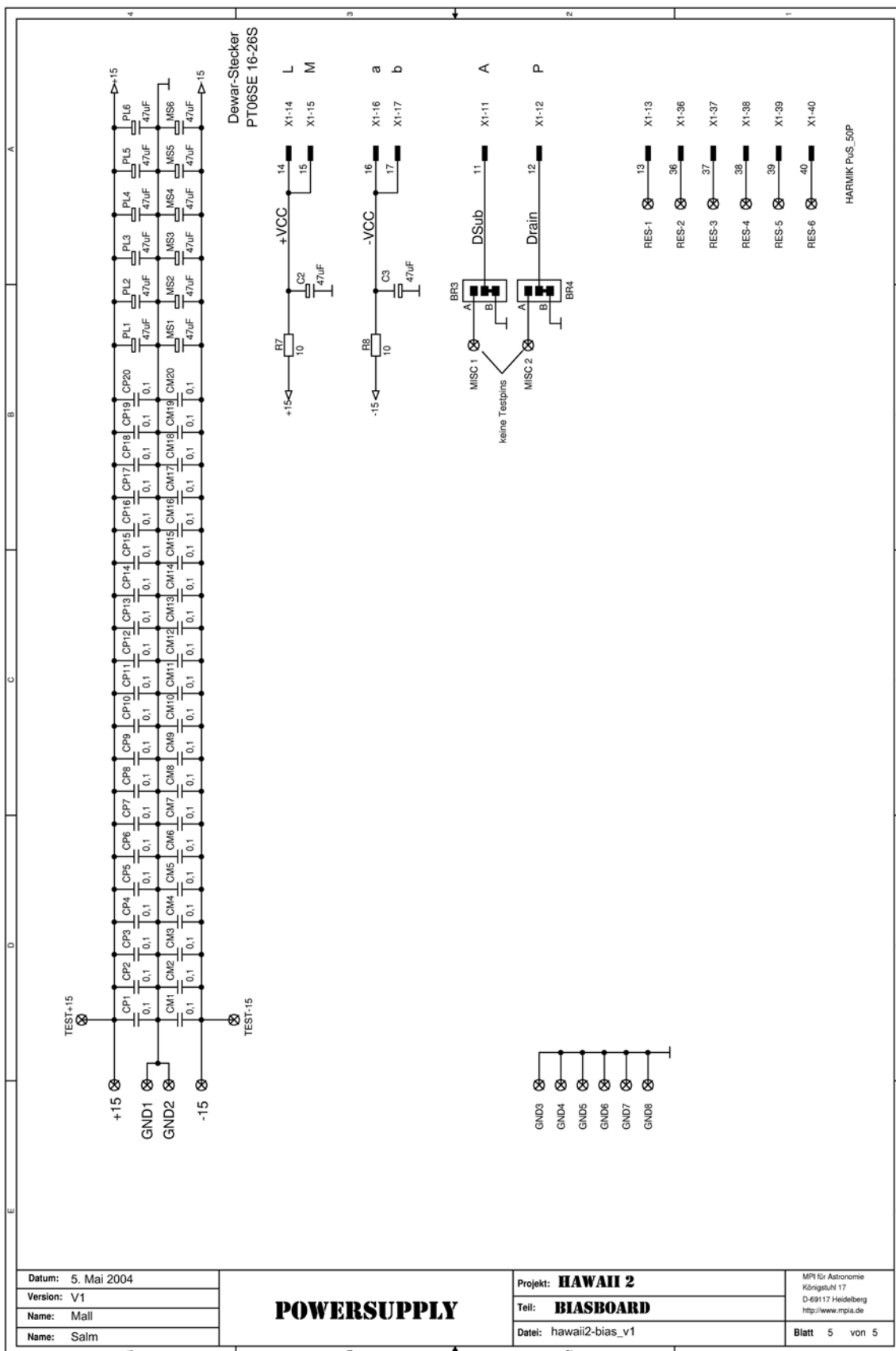

## 8 Clockbox

The clockboard is mounted in a aluminum box. Together they build the clockbox.

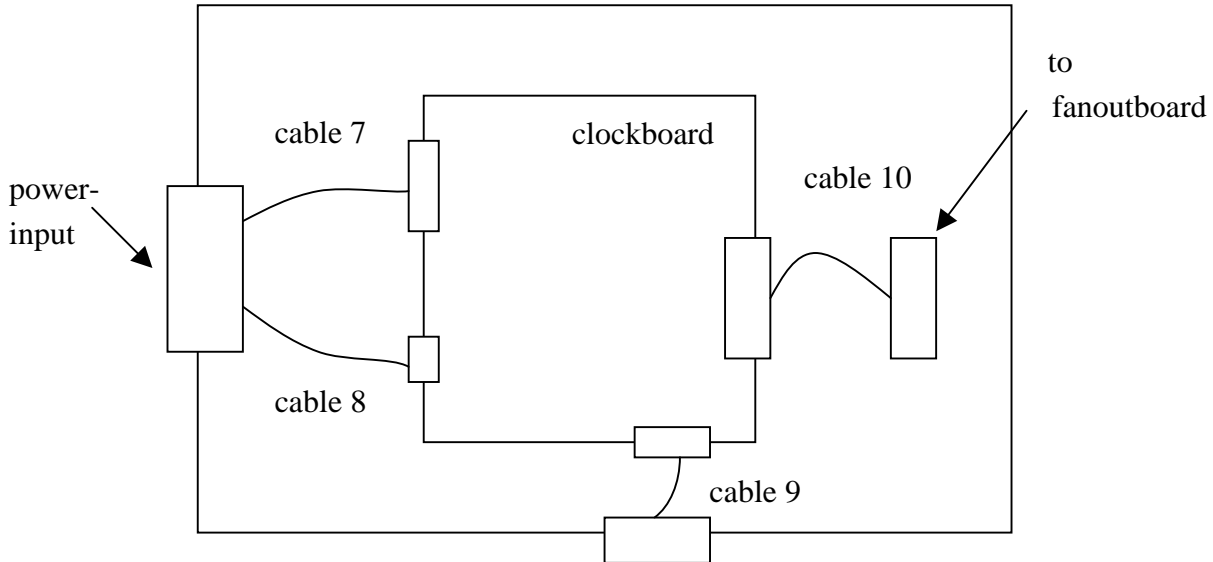

Figure 11 Clockbox overview

### 8.1 Clockbox Power Wiring

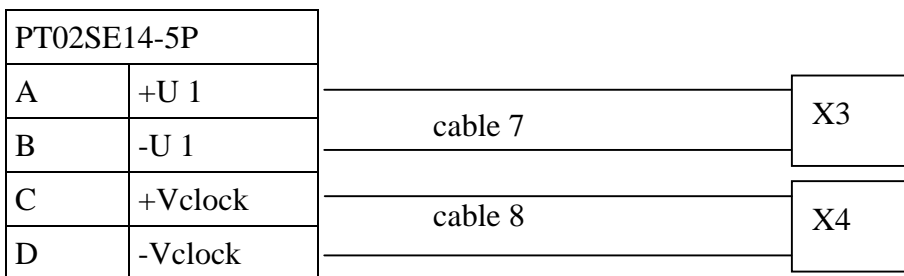

Figure 12 Clockbox cable 7 and 8

### 8.2 Clock Signal Cabling

The clocks from the pattern generator are connected to a PT02SE20-41S receptacle at the DACE with the following assignment:

Signal name	PT02SE20-41S
Clk1	c
GND	G
Clk2	a
GND	J
ClkB1	Y
GND	L
ClkB2	W
GND	N
Fsync	V
GND	R
Lsync	U
GND	X
Vclk	T
GND	Z
Reset	S
GND	b
Read	P
GND	d
Lrst	M
GND	f
O1	K
GND	h
O2	H
GND	j
Reseten	F
GND	m
Clkd Dr.	E
GND	p
+5V	k

Figure 13 Clock outlet at DACE

The clocks appear at the clockbox after passing a extension cable with the following assignment:

PT02SE20-41P	Signal name	PT02SE20-41S
c	Clk1	c
G	GND	G
a	Clk2	a
J	GND	J
Y	ClkB1	Y
L	GND	L
W	ClkB2	W
N	GND	N
V	Fsync	V
R	GND	R
U	Lsync	U
X	GND	X
T	Vclk	T
Z	GND	Z
S	Reset	S
b	GND	b
P	Read	P
d	GND	d
M	Lrst	M
f	GND	f
K	O1	K
h	GND	h
H	O2	H
j	GND	j
F	Reseten	F
m	GND	m
E	Clkd Dr.	E
p	GND	p
k	+5V	k

Figure 14 Clock extension cable

Before entering the clockboard the signals have to pass cable 9:

PT02SE20-41P	Signal name	AMP44S
c	Clk1	1
G	GND	23
a	Clk2	2
J	GND	24
Y	ClkB1	3
L	GND	25
W	ClkB2	4
N	GND	26
V	Fsync	5
R	GND	27
U	Lsync	6
X	GND	28
T	Vclk	7
Z	GND	29
S	Reset	8
b	GND	30
P	Read	9
d	GND	31
M	Lrst	10
f	GND	32
K	O1	11
h	GND	33
H	O2	12
j	GND	34
F	Reseten	13
m	GND	35
E	Clkd Dr.	14
p	GND	36
k	+5V	21

Figure 15 Clockbox cable 9

After being shaken on the clockboard the clocks pass cable 10 to finally reach the fanoutboard.

HARMIK PuS 50S	signal name	PT06SE18-32S
26	Clk1	B
27	Clk2	L
28	ClkB1	F
29	ClkB2	C
30	Fsync	G
31	Lsync	K
32	Vclk	E
33	Reset	D
34	Read	N
35	Lrst	J
36	O1	X
37	O2	Y
38	Reseten	H
39	Clkd Dr.	Z
40	clk_clamp	P
45	GND	A

Figure 16 Clockbox cable 10

### 8.3 Clockbox Schematics

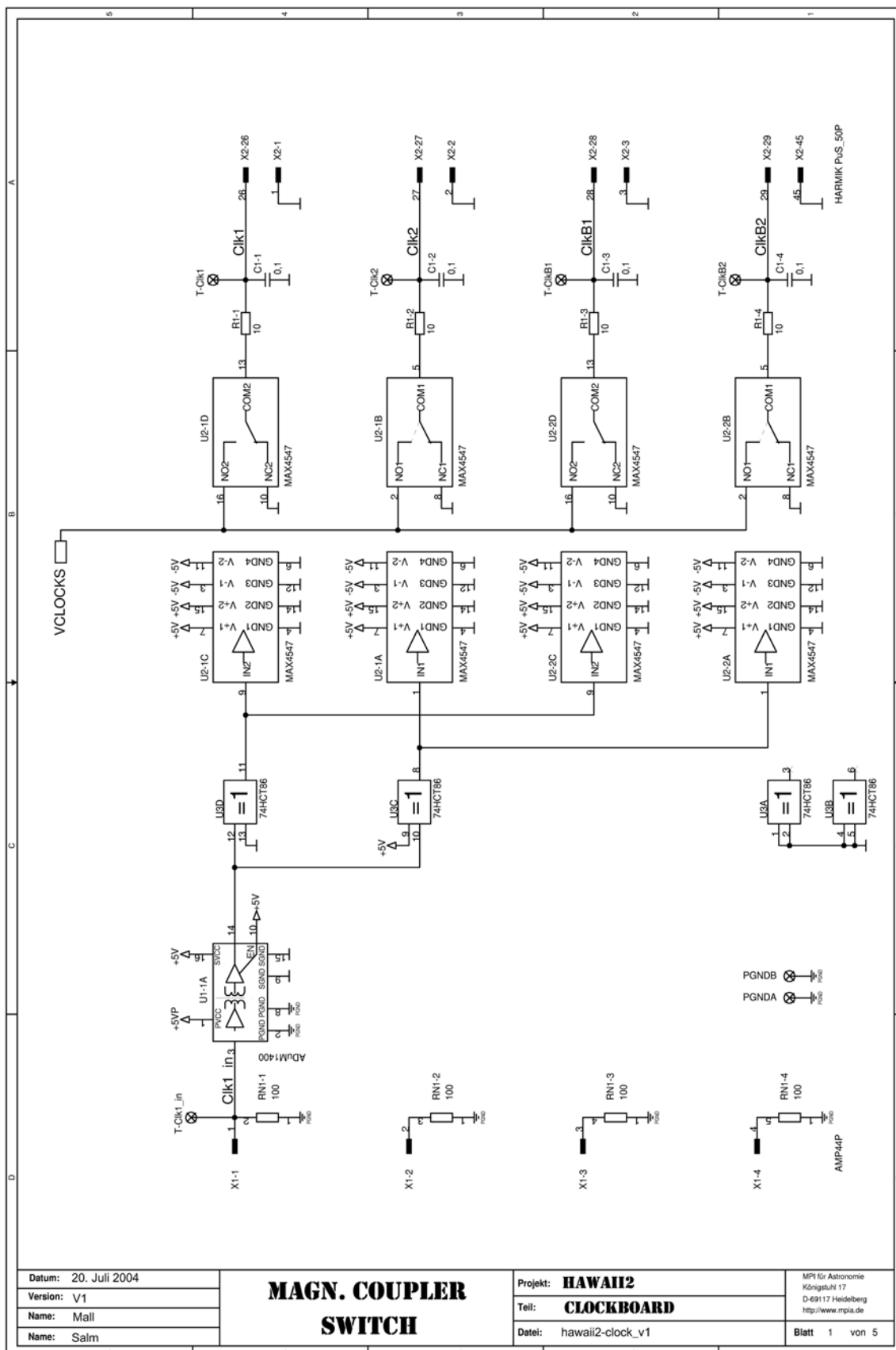

Datum:	20. Juli 2004
Version:	V1
Name:	Mall
Name:	Salm

## MAGN. COUPLER SWITCH

Projekt:	HAWAII2
Tel:	CLOCKBOARD
Dati:	hawaii2-clock_v1

MPI für Astronomie Königstuhl 17 D-69117 Heidelberg <a href="http://www.mpia.de">http://www.mpia.de</a>
Blatt 1 von 5

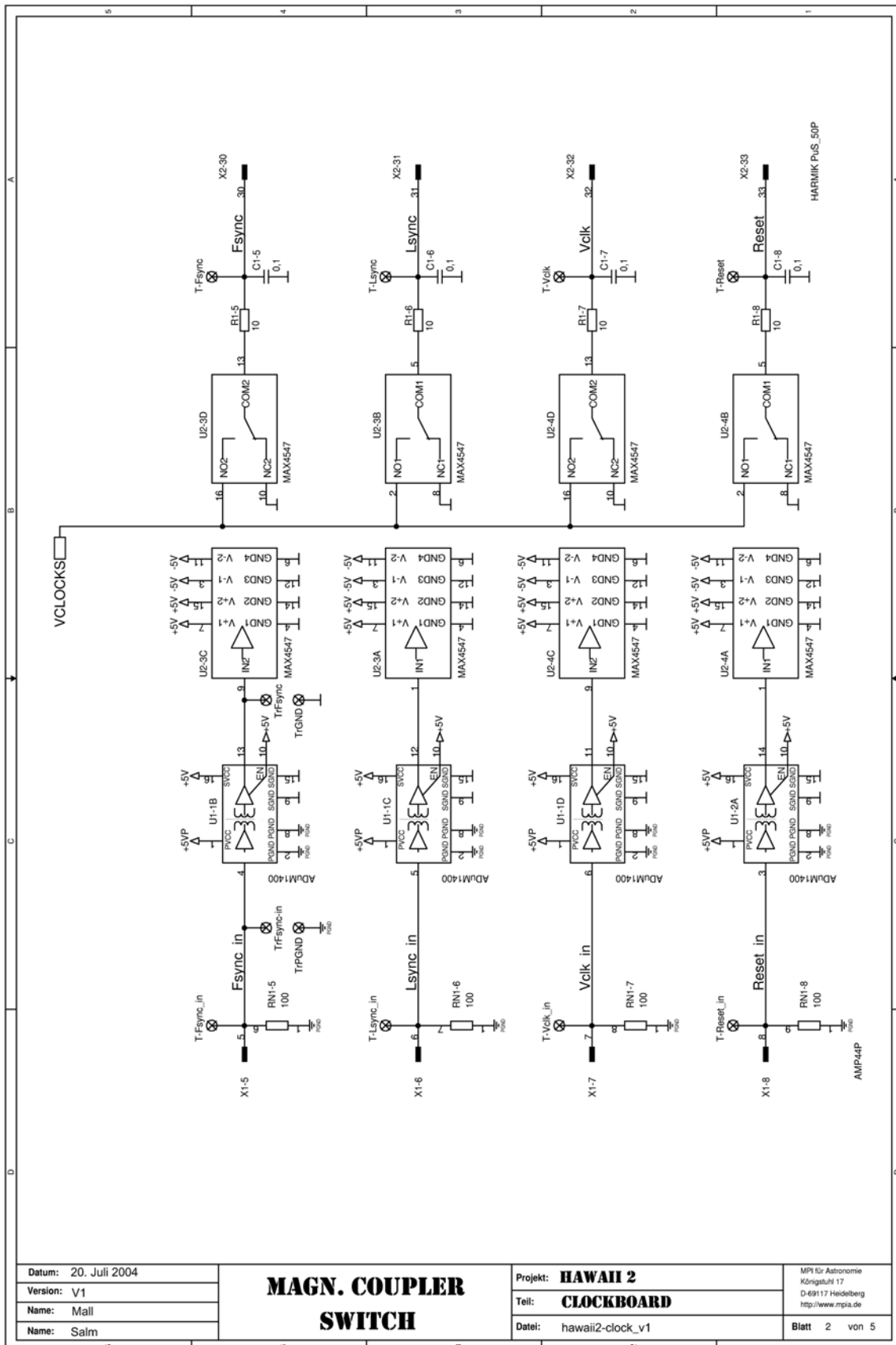



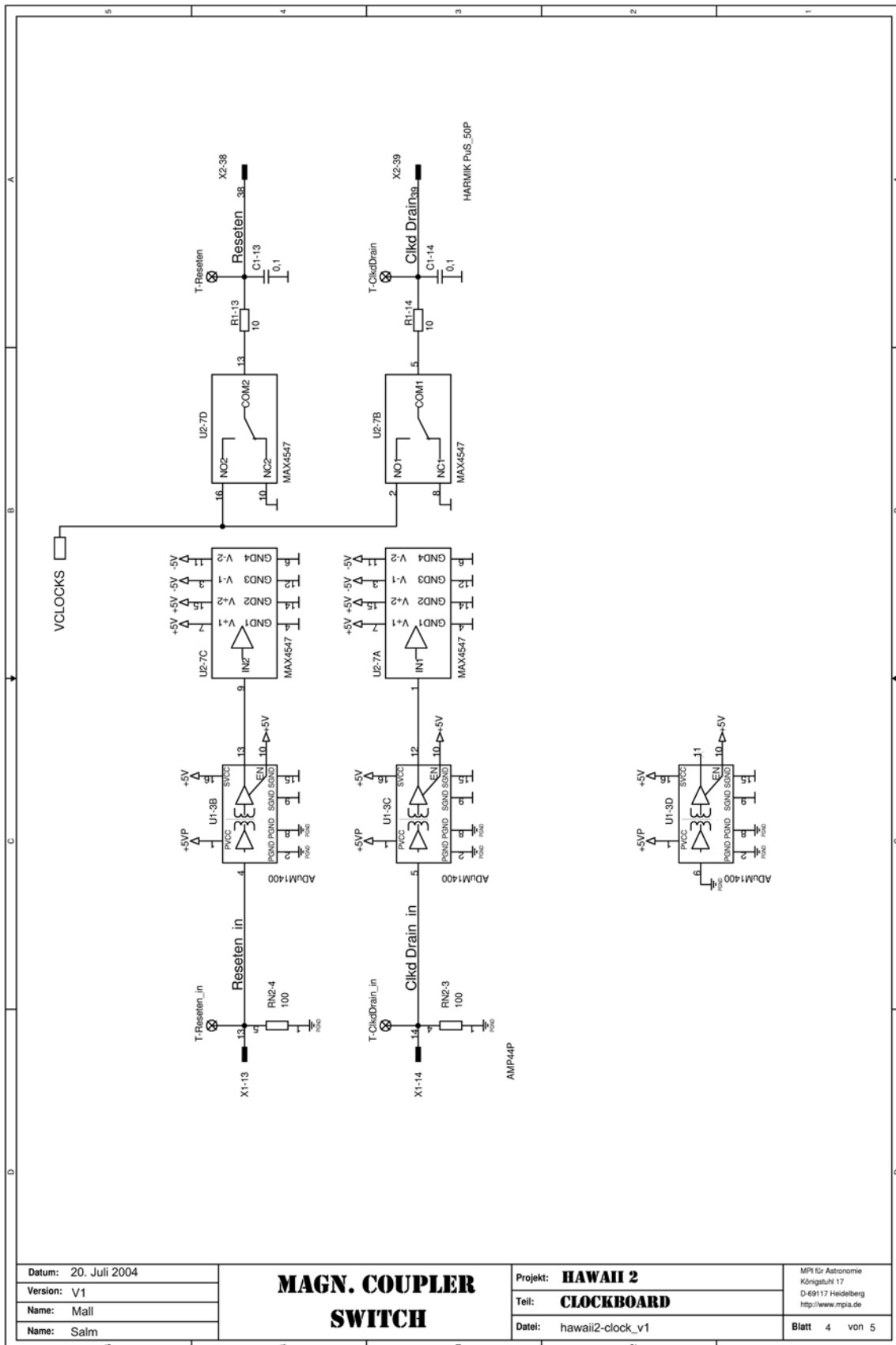

Datum:	20. Juli 2004
Version:	V1
Name:	Mall
Name:	Salm

**MAGN. COUPLER SWITCH**

Projekt:	<b>HAWAII 2</b>
Teil:	<b>CLOCKBOARD</b>
Datei:	hawaii2-clock_v1

MPI für Astronomie Königstuhl 17 D-69117 Heidelberg <a href="http://www.mpia.de">http://www.mpia.de</a>
Blatt 4 von 5

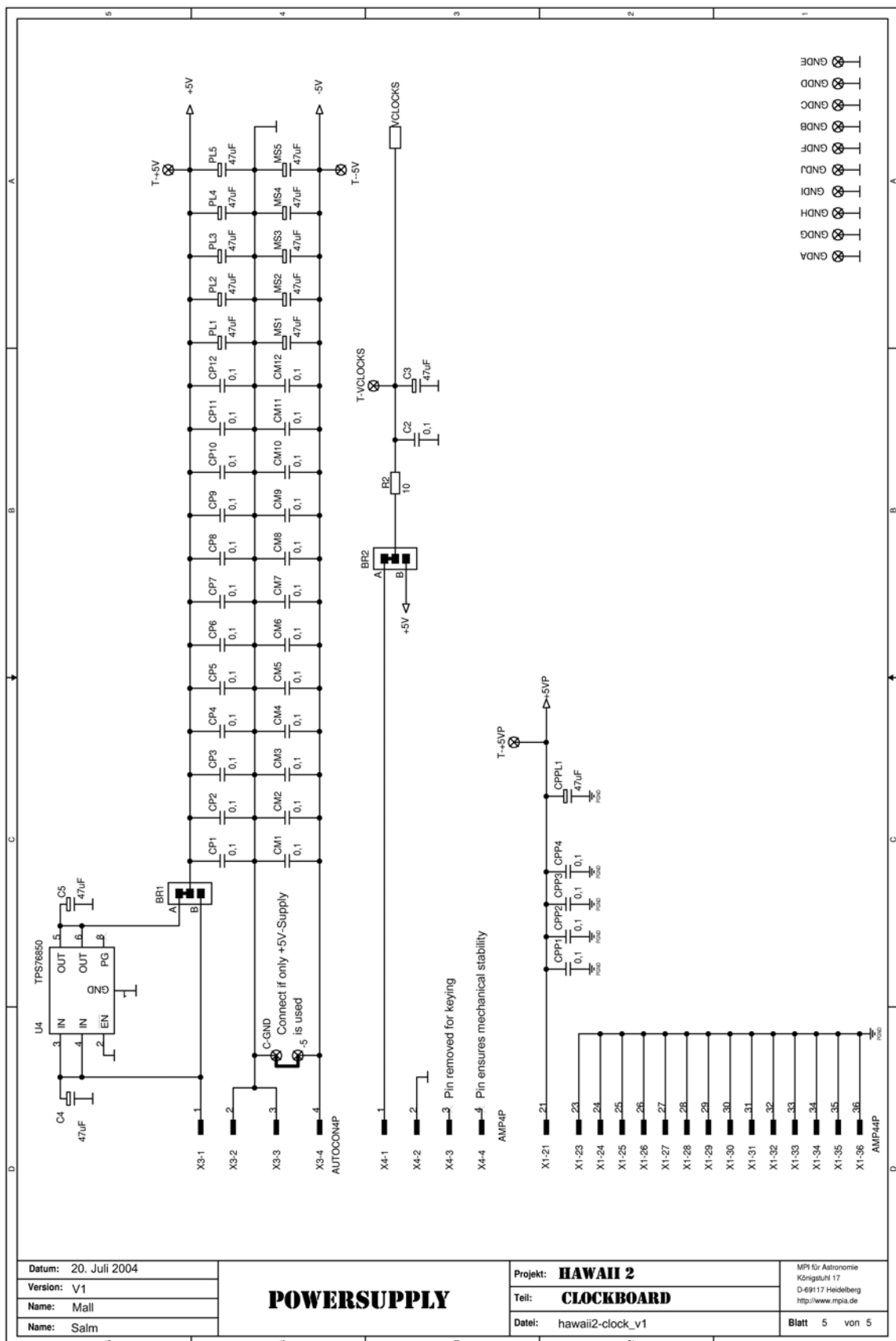

## 9 Dewar and Fanoutboard

Four hermetic receptacles connect the signals from and to the fanoutboard to the outside.

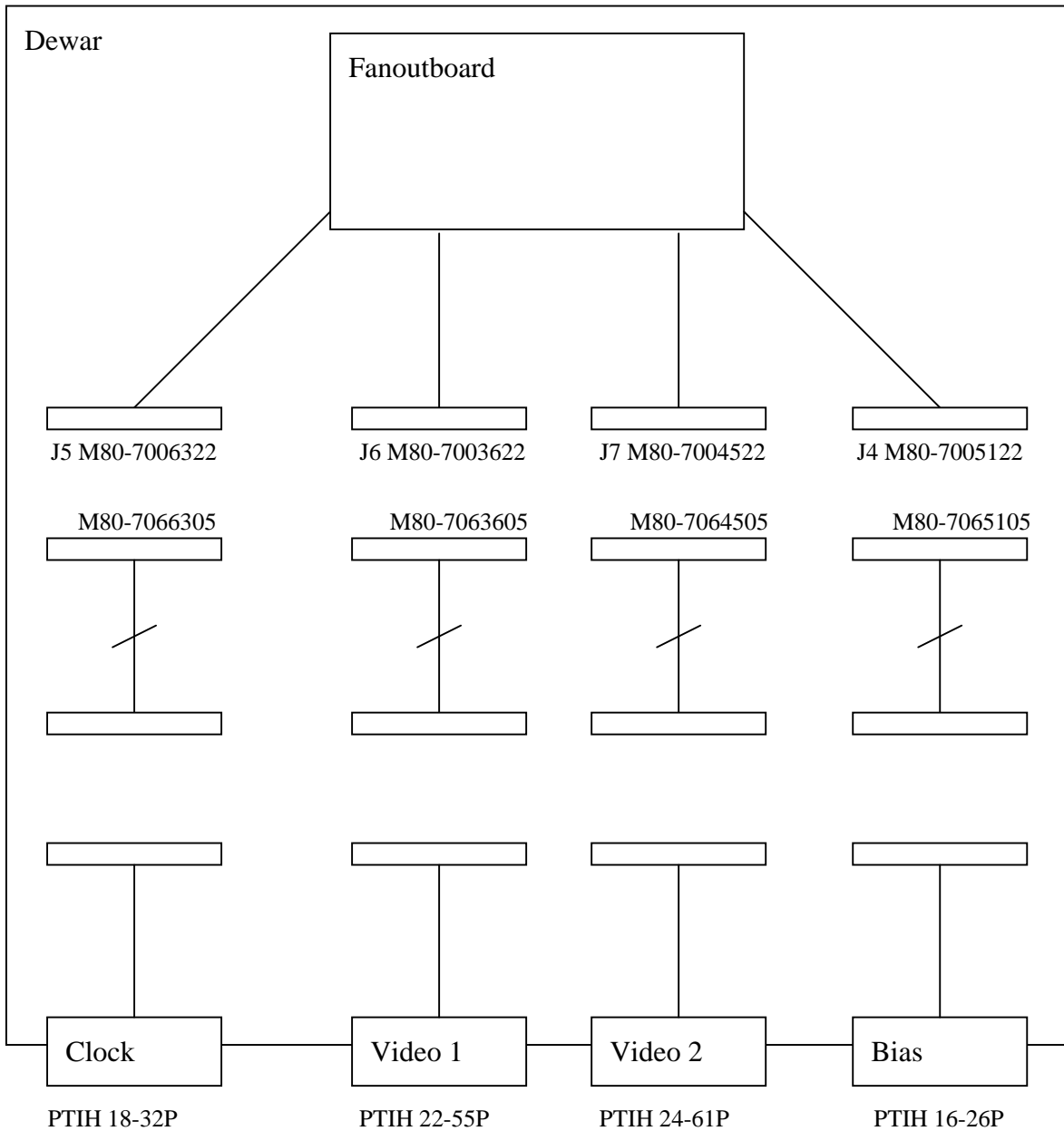

Figure 17 Fanoutboard cabling overview

## 9.1 Clock Cabling in the Dewar

The clocks enter the dewar through a 32 way hermetic connector and are routed to J5 on the fanoutboard with the following cable:

PTIH18-32P	signal name	J5
A	DGND	1
B	CLK1	2
C	CLKB2	3
D	RESET	6
E	VCLK	47
F	CLKB1	23
G	FSYNC	26
H	RESETEN	27
J	LRST	30
K	LSYNC	43
L	CLK2	46
M	VDD	7
N	READ	50
P	clk_clamp	51

Figure 18 Clock cabling in the dewar

## 9.2 Bias Cabling in the Dewar

The biases enter the dewar through a 26 way hermetic connector and are routed to J4 on the fanoutboard with the following cable:

PTIH 16-26P	signal name	J4
A	Dsub	1
B	GND	2
C	GND	3
D	VDDA	4
E	VLOAD2	5
F	GND	6
G	GND	7

H	ext_bias	8
J	GND	9
K	GND	10
c	VDD	11
L	+VCC	16
M	+VCC	17
N	Biasgate	20
P	Drain	21
R	GND	22
S	GND	23
T	VLOAD3	24
U	GND	33
V	GND	34
W	Vreset	36
X	Biaspower	37
Y	VLOAD1	40
Z	VLOAD4	41
a	-VCC	50
b	-VCC	51

Figure 19 Bias cabling in the dewar

### 9.3 Video Cabling in the Dewar

The detector output signals are converted from single ended to differential on the fanoutboard and routed to the connectors J6 and J7. From there they are connected to two hermetic receptacles with the following cables:

PTIH 22-55P	signal name	J6
A	Video GND	13
B	PRE GND	21
C	Schirm	
D	Sig+1	27
E	Sig-1	28
F	Sig+2	16
G	Sig-2	17

H	Sig+3	18
J	Sig-3	6
K	Sig+4	7
L	Sig-4	32
M	Sig+5	25
N	Sig-5	26
P	Sig+6	1
R	Sig-6	2
S	Sig+7	14
T	Sig-7	15
U	Sig+8	3
V	Sig-8	4
W	Sig+9	5
X	Sig-9	30
Y	Sig+10	31
Z	Sig-10	19
a	Sig+11	20
b	Sig-11	8
c	Sig+33	10
d	Sig-33	11
e	Sig+34	22
f	Sig-34	23
g	Sig+35	35
h	Sig-35	12
i	Sig+36	36
j	Sig-36	24

Figure 20 Video 1 cabling in the dewar

PTIH 24-61P	signal name	J7
A	Video GND	16
B	PRE GND	30
C	Schirm	
D	Sig+12	1
E	Sig-12	2





F	Sig+13	31
G	Sig-13	32
H	Sig+14	17
J	Sig-14	18
K	Sig+15	3
L	Sig-15	4
M	Sig+16	33
N	Sig-16	34
P	Sig+17	19
R	Sig-17	20
S	Sig+18	5
T	Sig-18	6
U	Sig+19	35
V	Sig-19	36
W	Sig+20	21
X	Sig-20	22
Y	Sig+21	7
Z	Sig-21	8
a	Sig+22	37
b	Sig-22	38
c	Sig+23	9
d	Sig-23	24
e	Sig+24	39
f	Sig-24	10
g	Sig+25	25
h	Sig-25	40
i	Sig+26	11
j	Sig-26	26
k	Sig+27	41
m	Sig-27	12
n	Sig+28	27
p	Sig-28	42
q	Sig+29	13
r	Sig-29	28



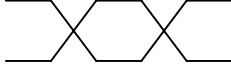
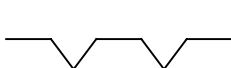
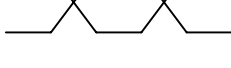
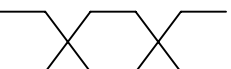
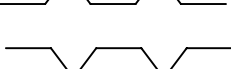
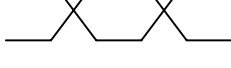
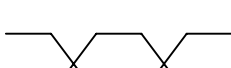
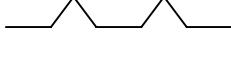
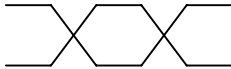
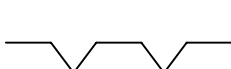
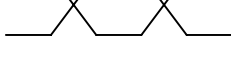
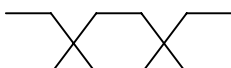
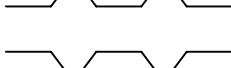
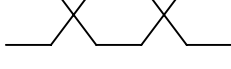
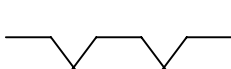
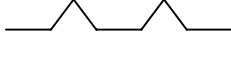
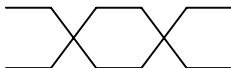
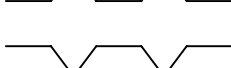
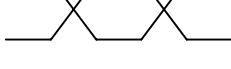
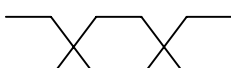
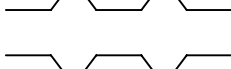
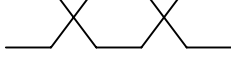
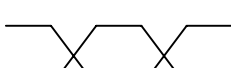
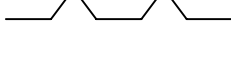

s	Sig+30	43
t	Sig-30	14
u	Sig+31	29
v	Sig-31	44
w	Sig+32	45
x	Sig-32	15

Figure 21 Video 2 cabling in the dewar

## 9.4 Video Cabling from Dewar to DACE

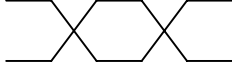
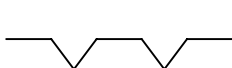
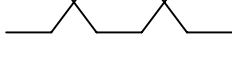
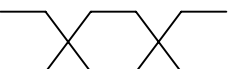
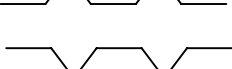
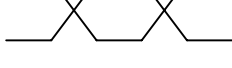
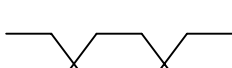
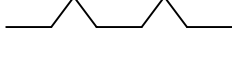
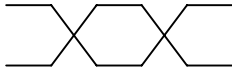
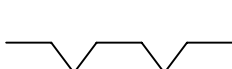
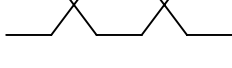
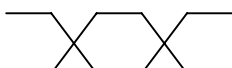
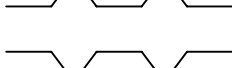
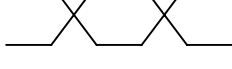
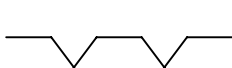
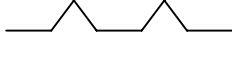
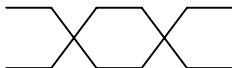
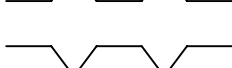
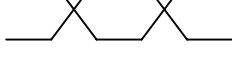
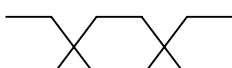
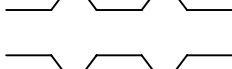
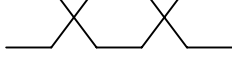
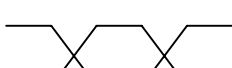
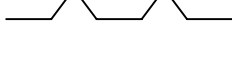
Finally the video signals are routed to the DACE with the following two cables:

PT06SE22-55S	
A	_____
B	_____
C	_____
D	
E	
F	
G	
H	
J	
K	
L	
M	
N	
P	
R	
S	
T	
U	
V	
W	
X	
Y	
Z	
a	
b	
c	
d	
e	
f	
g	
h	
i	
j	

signal name	
Video GND	_____
PRE GND	_____
Schirm	_____
Sig+1	
Sig-1	
Sig+2	
Sig-2	
Sig+3	
Sig-3	
Sig+4	
Sig-4	
Sig+5	
Sig-5	
Sig+6	
Sig-6	
Sig+7	
Sig-7	
Sig+8	
Sig-8	
Sig+9	
Sig-9	
Sig+10	
Sig-10	
Sig+11	
Sig-11	
Sig+33	
Sig-33	
Sig+34	
Sig-34	
Sig+35	
Sig-35	
Sig+36	
Sig-36	

PT06SE22-55P	
A	
B	
C	
D	
E	
F	
G	
H	
J	
K	
L	
M	
N	
P	
R	
S	
T	
U	
V	
W	
X	
Y	
Z	
a	
b	
c	
d	
e	
f	
g	
h	
i	
j	

PT06SE24-61S	signal name
A	Video GND
B	PRE GND
C	Schirm
D	Sig+1
E	Sig-1
F	Sig+2
G	Sig-2
H	Sig+3
J	Sig-3
K	Sig+4
L	Sig-4
M	Sig+5
N	Sig-5
P	Sig+6
R	Sig-6
S	Sig+7
T	Sig-7
U	Sig+8
V	Sig-8
W	Sig+9
X	Sig-9
Y	Sig+10
Z	Sig-10
a	Sig+11
b	Sig-11
c	Sig+33
d	Sig-33
e	Sig+34
f	Sig-34
g	Sig+35
h	Sig-35
i	Sig+36

j	Sig-36
k	
m	
n	
p	
q	
r	
s	
t	
u	
v	
w	
x	